

同步带模组 (半密封) -HB13M

Timing Belt Module (semi-sealed)

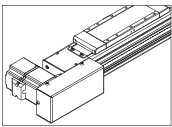

电机安装方式 How the Motor is Installed



电机左折-L
Motor left side

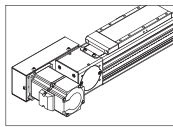

电机右折-R
Motor right side

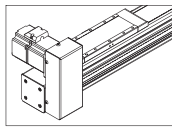

电机左上折-LU
Motor folds on the upper left

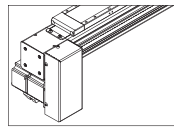

电机左下折-LD
Motor folds down left

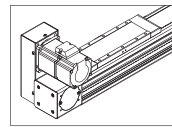

电机右上折-RU
Motor folds up on the right

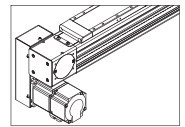

电机右下折-RD
Motor folds down on the right

型号表示方式 Guide for Model Selection

Z-Mod-HB13M-45-100-L-40SEB-N3-FXXX-01

HB13M	45	100	L	40SE	B	N3	FXXX-01
本体型号 Base Model	导程 Lead 45: 45mm *导程: 电机旋转一圈, 滑台移动的直线距离。	行程 Stroke 100-3100mm	电机方式 Motor way L: 左折 R: 右折 LU: 左上折 LD: 左下折 RU: 右上折 RD: 右下折	电机功率 Motor power 40SE: 400W伺服	刹车 Brakes 无: 无电机 B: 一体式电机 (带刹车) M: 一体式电机	感应开关数量 Sensor quantity N3: 3个NPN传感器 N2: 2个NPN传感器 N1: 1个NPN传感器 P3: 3个PNP传感器 P2: 2个PNP传感器 P1: 1个PNP传感器 N: 无	特殊定制 Customer number F: 非标定制选项, 若为标准品, 则为空 XXX: 客户标号 01: 版本号

基本参数 Parameters

电机转速 Motor speed(rpm/min)	500	1000	1500	2000	2500	3000
最高速度 Maximum payload(mm/s)	375	750	1125	1500	1875	2250
最大负载 Rated load(kg)(水平使用)	30	30	23	20	15	10
重复位置精度 Repeatability(mm)	±0.04					
*导程 Lead(mm)	45					
额定推力 Rated thrust(N)	160					
行程范围 Range of travel(mm)	100-3100MM/50行程递增					
电机功率 Motor output(W)	400					
皮带宽度 Synchro band width(mm)	20					
导轨规格 Guide specification	W15XH12-2支					
感应器 Sensor	EE-SX674(NPN)					

- *导程: 电机旋转一圈, 滑台移动的直线距离。
*Guide: the rotation of the motor and the straight distance of the sliding table.
- *电机加减速时间为0.4S。
*Motor speed is 0.4S.
- *如有特殊定制请先与技术人员联系。
If you have special customization, please contact a technician first.

传感器接线图 Sensor Wiring Diagram

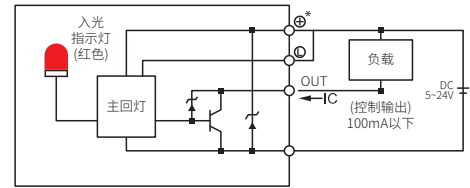

负载与速度 Load and Speed

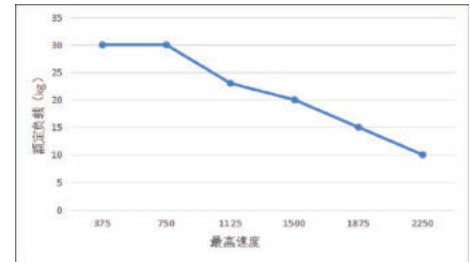

安装示意图 Installation Diagram

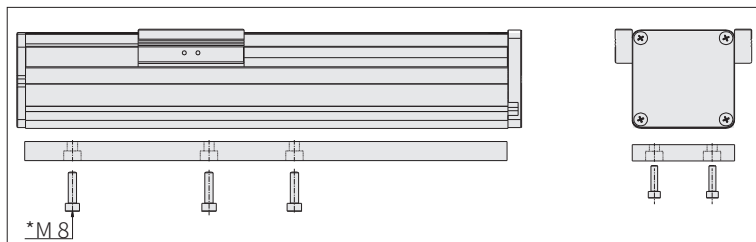

- 安装方式一: 安装螺丝从下往上安装。
Installation method 1: The screws are installed from bottom to bottom.
- *注意锁紧螺丝装入滑台的长度不得超过11mm, 否则会内部干涉。
Note that the length of the locking screw installed in the slide shall not exceed 11mm, otherwise it will interfere with the internal.

静态力矩表 Static Moment

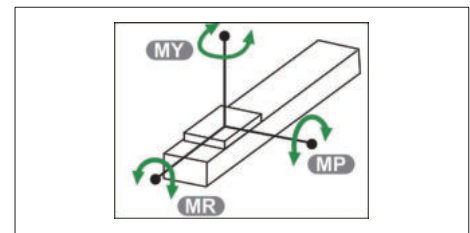

MY	550 (N.M)
MP	550 (N.M)
MR	480 (N.M)

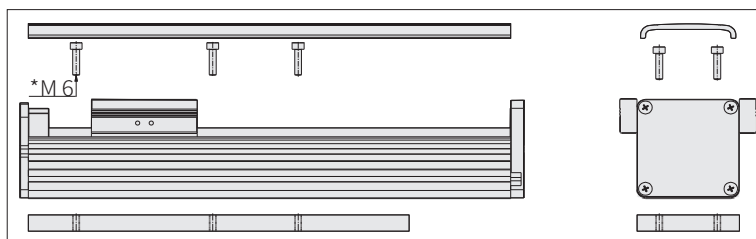

- 安装方式二: 打开滑台上盖, 安装螺丝从上往下安装。
Installation method 2: Open the sliding table cover and install the screws from top to bottom.

电机左折-L Motor Left Side

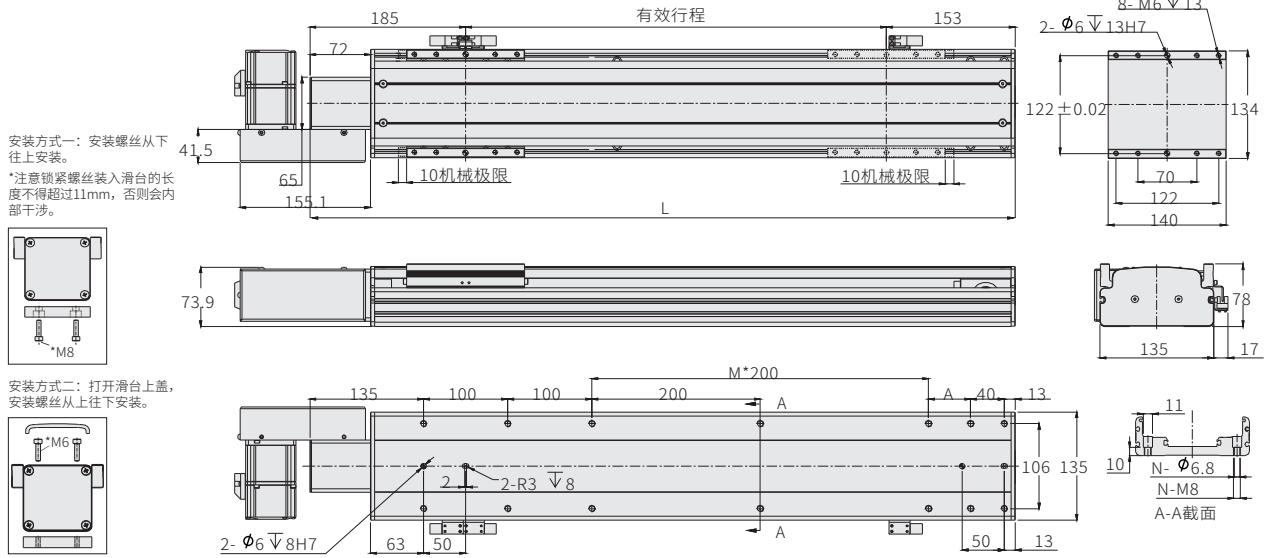

有效行程	50	100	150	200	250	300	350	400	450	500	550	600	650	700	750	800	850	900	950	1000	1050	1100	1150	1200	1250	1300	1350	1400	1450	1500	1550
L	388	438	488	538	588	638	688	738	788	838	888	938	988	1038	1088	1138	1188	1238	1288	1338	1388	1438	1488	1538	1588	1638	1688	1738	1788	1838	1888
A	0	50	100	150	200	50	100	150	200	50	100	150	200	50	100	150	200	50	100	150	200	50	100	150	200	50	100	150	200	50	100
M	0	0	0	0	0	1	1	1	1	2	2	2	2	3	3	3	3	4	4	4	4	5	5	5	5	6	6	6	6	7	7
N	8	10	10	10	10	12	12	12	12	14	14	14	14	16	16	16	16	18	18	18	18	20	20	20	20	22	22	22	22	24	24
KG	7.3	7.8	8.3	8.8	9.3	9.8	10.3	10.8	11.3	11.8	12.3	12.8	13.3	13.8	14.3	14.8	15.3	15.8	16.3	16.8	17.3	17.8	18.3	18.8	19.3	19.8	20.3	20.8	21.3	21.8	22.3
有效行程	1600	1650	1700	1750	1800	1850	1900	1950	2000	2050	2100	2150	2200	2250	2300	2350	2400	2450	2500	2550	2600	2650	2700	2750	2800	2850	2900	2950	3000	3050	3100
L	1938	1988	2038	2088	2138	2188	2238	2288	2338	2388	2438	2488	2538	2588	2638	2688	2738	2788	2838	2888	2938	2988	3038	3088	3138	3188	3238	3288	3338	3388	3438
A	150	200	50	100	150	200	50	100	150	200	50	100	150	200	50	100	150	200	50	100	150	200	50	100	150	200	50	100	150	200	50
M	7	7	8	8	8	8	9	9	9	9	10	10	10	10	11	11	11	11	12	12	12	12	13	13	13	13	14	14	14	14	15
N	24	24	26	26	26	26	28	28	28	28	30	30	30	30	32	32	32	32	34	34	34	34	36	36	36	36	38	38	38	38	40
KG	22.8	23.3	23.8	24.3	24.8	25.3	25.8	26.3	26.8	27.3	27.8	28.3	28.8	29.3	29.8	30.3	30.8	31.3	31.8	32.3	32.8	33.3	33.8	34.3	34.8	35.3	35.8	36.3	36.8	37.3	37.8

注：以上不含电机重量。
Note: Not including motor weight.

电机右折-R Motor Right Side

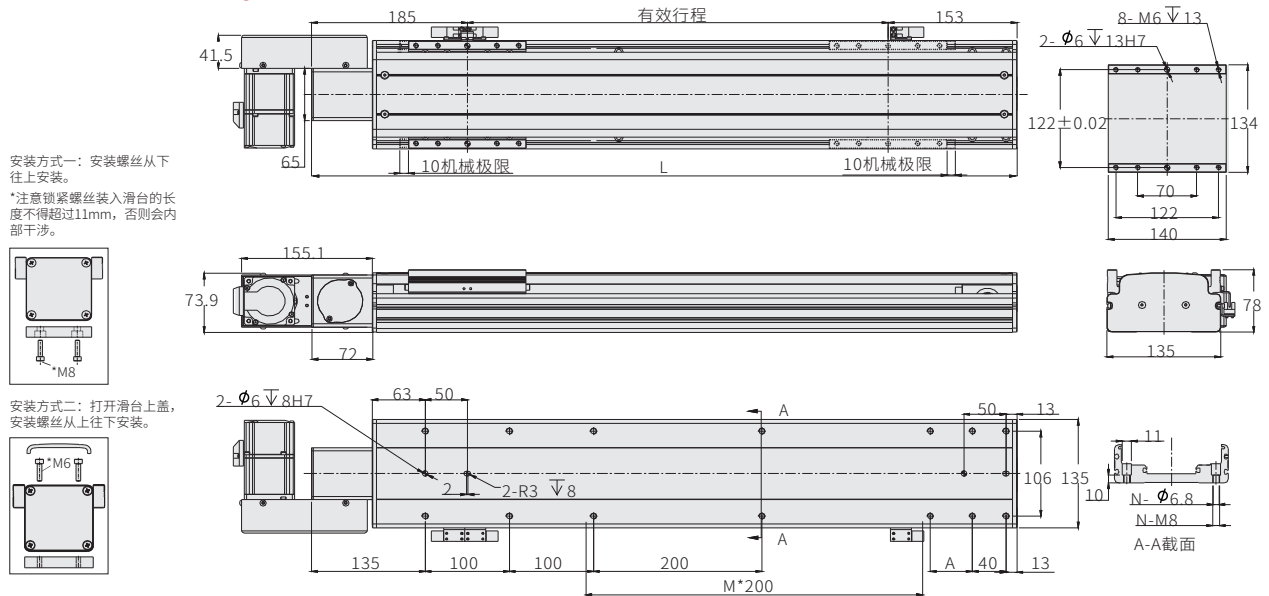

有效行程	50	100	150	200	250	300	350	400	450	500	550	600	650	700	750	800	850	900	950	1000	1050	1100	1150	1200	1250	1300	1350	1400	1450	1500	1550
L	388	438	488	538	588	638	688	738	788	838	888	938	988	1038	1088	1138	1188	1238	1288	1338	1388	1438	1488	1538	1588	1638	1688	1738	1788	1838	1888
A	0	50	100	150	200	50	100	150	200	50	100	150	200	50	100	150	200	50	100	150	200	50	100	150	200	50	100	150	200	50	100
M	0	0	0	0	0	1	1	1	1	2	2	2	2	3	3	3	3	4	4	4	4	5	5	5	5	6	6	6	6	7	7
N	8	10	10	10	10	12	12	12	12	14	14	14	14	16	16	16	16	18	18	18	18	20	20	20	20	22	22	22	22	24	24
KG	7.3	7.8	8.3	8.8	9.3	9.8	10.3	10.8	11.3	11.8	12.3	12.8	13.3	13.8	14.3	14.8	15.3	15.8	16.3	16.8	17.3	17.8	18.3	18.8	19.3	19.8	20.3	20.8	21.3	21.8	22.3
有效行程	1600	1650	1700	1750	1800	1850	1900	1950	2000	2050	2100	2150	2200	2250	2300	2350	2400	2450	2500	2550	2600	2650	2700	2750	2800	2850	2900	2950	3000	3050	3100
L	1938	1988	2038	2088	2138	2188	2238	2288	2338	2388	2438	2488	2538	2588	2638	2688	2738	2788	2838	2888	2938	2988	3038	3088	3138	3188	3238	3288	3338	3388	3438
A	150	200	50	100	150	200	50	100	150	200	50	100	150	200	50	100	150	200	50	100	150	200	50	100	150	200	50	100	150	200	50
M	7	7	8	8	8	8	9	9	9	9	10	10	10	10	11	11	11	11	12	12	12	12	13	13	13	13	14	14	14	14	15
N	24	24	26	26	26	26	28	28	28	28	30	30	30	30	32	32	32	32	34	34	34	34	36	36	36	36	38	38	38	38	40
KG	22.8	23.3	23.8	24.3	24.8	25.3	25.8	26.3	26.8	27.3	27.8	28.3	28.8	29.3	29.8	30.3	30.8	31.3	31.8	32.3	32.8	33.3	33.8	34.3	34.8	35.3	35.8	36.3	36.8	37.3	37.8

注：以上不含电机重量。
Note: Not including motor weight.

电机左上折-LU Motor Folds on the Upper Left

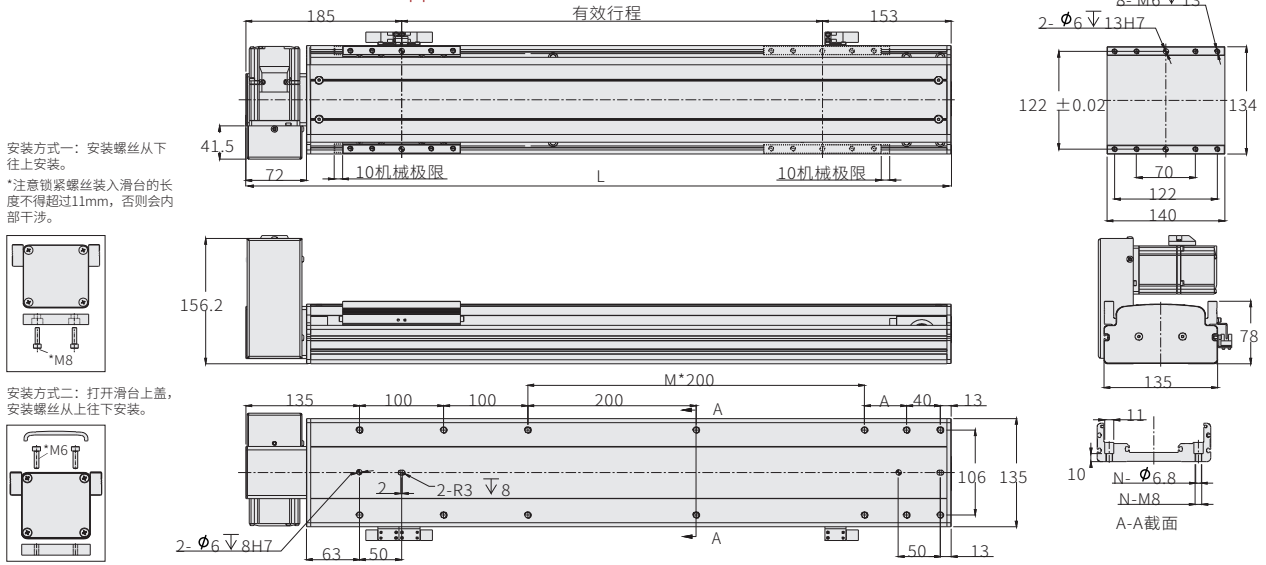

有效行程	50	100	150	200	250	300	350	400	450	500	550	600	650	700	750	800	850	900	950	1000	1050	1100	1150	1200	1250	1300	1350	1400	1450	1500	1550	
L	388	438	488	538	588	638	688	738	788	838	888	938	988	1038	1088	1138	1188	1238	1288	1338	1388	1438	1488	1538	1588	1638	1688	1738	1788	1838	1888	
A	0	50	100	150	200	50	100	150	200	50	100	150	200	50	100	150	200	50	100	150	200	50	100	150	200	50	100	150	200	50	100	
M	0	0	0	0	0	1	1	1	1	2	2	2	2	3	3	3	3	4	4	4	4	5	5	5	5	6	6	6	6	7	7	
N	8	10	10	10	10	12	12	12	12	14	14	14	14	16	16	16	16	18	18	18	18	20	20	20	20	22	22	22	22	24	24	
KG	7.3	7.8	8.3	8.8	9.3	9.8	10.3	10.8	11.3	11.8	12.3	12.8	13.3	13.8	14.3	14.8	15.3	15.8	16.3	16.8	17.3	17.8	18.3	18.8	19.3	19.8	20.3	20.8	21.3	21.8	22.3	
有效行程	1600	1650	1700	1750	1800	1850	1900	1950	2000	2050	2100	2150	2200	2250	2300	2350	2400	2450	2500	2550	2600	2650	2700	2750	2800	2850	2900	2950	3000	3050	3100	
L	1938	1988	2038	2088	2138	2188	2238	2288	2338	2388	2438	2488	2538	2588	2638	2688	2738	2788	2838	2888	2938	2988	3038	3088	3138	3188	3238	3288	3338	3388	3438	
A	150	200	50	100	150	200	50	100	150	200	50	100	150	200	50	100	150	200	50	100	150	200	50	100	150	200	50	100	150	200	50	
M	7	7	8	8	8	8	9	9	9	9	10	10	10	10	11	11	11	11	12	12	12	12	13	13	13	13	14	14	14	14	15	
N	24	24	26	26	26	26	28	28	28	28	30	30	30	30	32	32	32	32	34	34	34	34	34	36	36	36	36	38	38	38	38	40
KG	22.8	23.3	23.8	24.3	24.8	25.3	25.8	26.3	26.8	27.3	27.8	28.3	28.8	29.3	29.8	30.3	30.8	31.3	31.8	32.3	32.8	33.3	33.8	34.3	34.8	35.3	35.8	36.3	36.8	37.3	37.8	

注：以上不含电机重量。
Note: Not including motor weight.

电机左下折-LD Motor Folds Down Deft

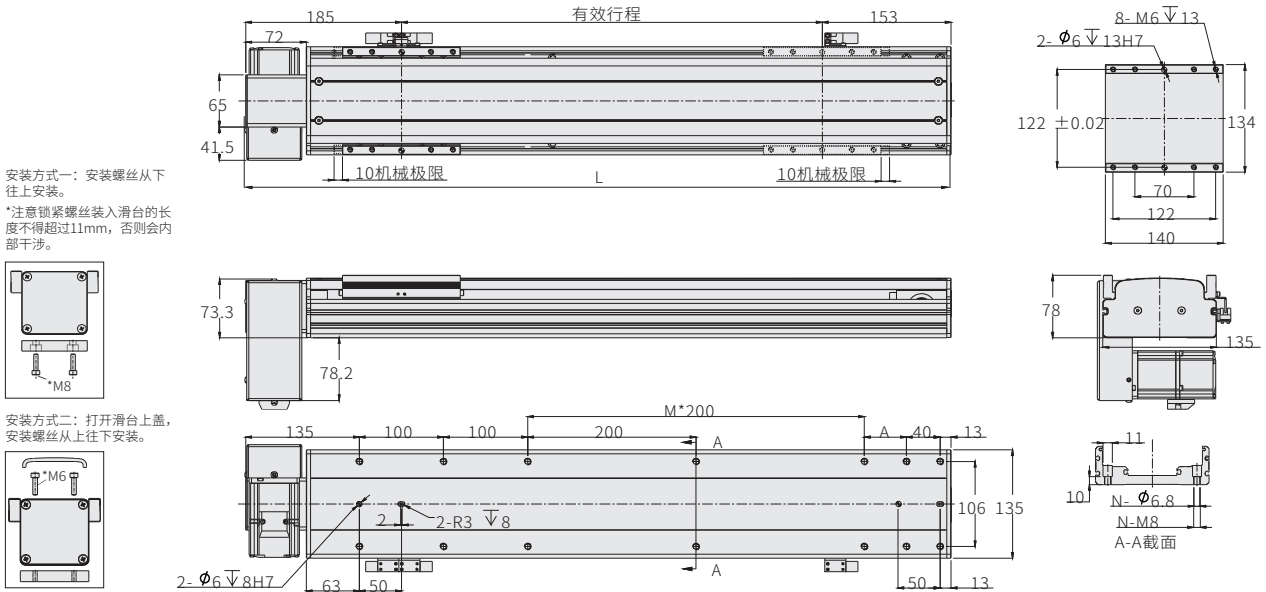

有效行程	50	100	150	200	250	300	350	400	450	500	550	600	650	700	750	800	850	900	950	1000	1050	1100	1150	1200	1250	1300	1350	1400	1450	1500	1550	
L	388	438	488	538	588	638	688	738	788	838	888	938	988	1038	1088	1138	1188	1238	1288	1338	1388	1438	1488	1538	1588	1638	1688	1738	1788	1838	1888	
A	0	50	100	150	200	50	100	150	200	50	100	150	200	50	100	150	200	50	100	150	200	50	100	150	200	50	100	150	200	50	100	
M	0	0	0	0	0	1	1	1	1	2	2	2	2	3	3	3	3	4	4	4	4	5	5	5	5	6	6	6	6	7	7	
N	8	10	10	10	10	12	12	12	12	14	14	14	14	16	16	16	16	18	18	18	18	20	20	20	20	22	22	22	22	24	24	
KG	7.3	7.8	8.3	8.8	9.3	9.8	10.3	10.8	11.3	11.8	12.3	12.8	13.3	13.8	14.3	14.8	15.3	15.8	16.3	16.8	17.3	17.8	18.3	18.8	19.3	19.8	20.3	20.8	21.3	21.8	22.3	
有效行程	1600	1650	1700	1750	1800	1850	1900	1950	2000	2050	2100	2150	2200	2250	2300	2350	2400	2450	2500	2550	2600	2650	2700	2750	2800	2850	2900	2950	3000	3050	3100	
L	1938	1988	2038	2088	2138	2188	2238	2288	2338	2388	2438	2488	2538	2588	2638	2688	2738	2788	2838	2888	2938	2988	3038	3088	3138	3188	3238	3288	3338	3388	3438	
A	150	200	50	100	150	200	50	100	150	200	50	100	150	200	50	100	150	200	50	100	150	200	50	100	150	200	50	100	150	200	50	
M	7	7	8	8	8	8	9	9	9	9	10	10	10	10	11	11	11	11	12	12	12	12	13	13	13	13	14	14	14	14	15	
N	24	24	26	26	26	26	28	28	28	28	30	30	30	30	32	32	32	32	34	34	34	34	34	36	36	36	36	38	38	38	38	40
KG	22.8	23.3	23.8	24.3	24.8	25.3	25.8	26.3	26.8	27.3	27.8	28.3	28.8	29.3	29.8	30.3	30.8	31.3	31.8	32.3	32.8	33.3	33.8	34.3	34.8	35.3	35.8	36.3	36.8	37.3	37.8	

注：以上不含电机重量。
Note: Not including motor weight.

电机右上折-RU Motor Folds up on the Right

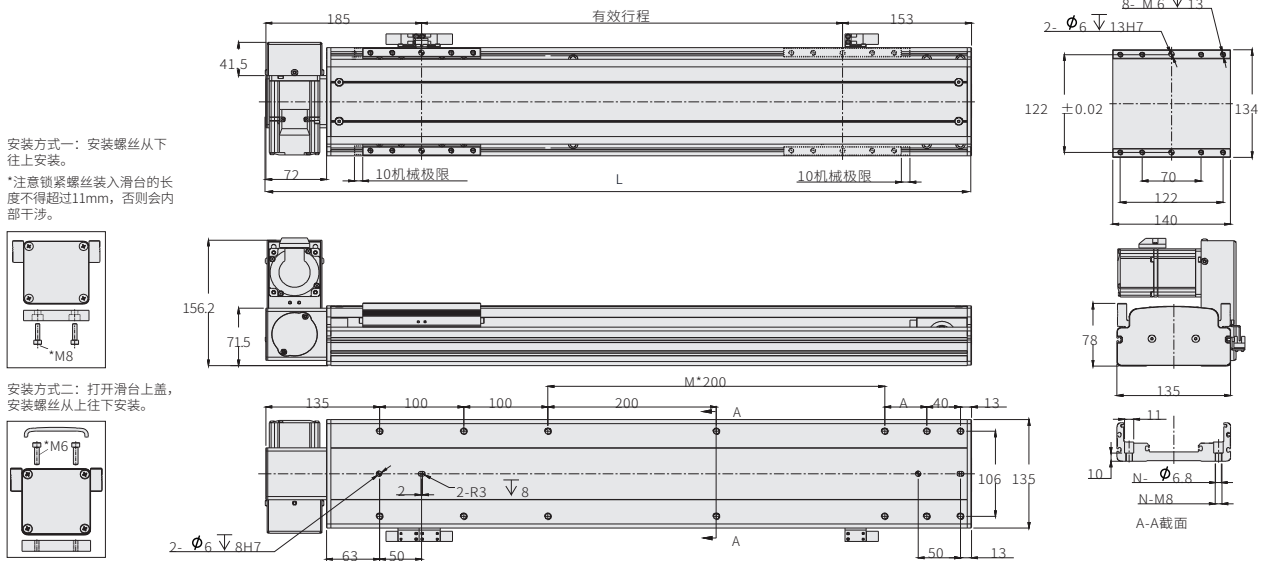

安装方式一：安装螺丝从下往上安装。
*注意锁紧螺丝装入滑台的长度不得超过11mm，否则会影响内部干涉。

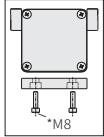

安装方式二：打开滑台上盖，安装螺丝从上往下安装。

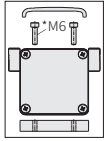

有效行程	50	100	150	200	250	300	350	400	450	500	550	600	650	700	750	800	850	900	950	1000	1050	1100	1150	1200	1250	1300	1350	1400	1450	1500	1550	
L	388	438	488	538	588	638	688	738	788	838	888	938	988	1038	1088	1138	1188	1238	1288	1338	1388	1438	1488	1538	1588	1638	1688	1738	1788	1838	1888	
A	0	50	100	150	200	50	100	150	200	50	100	150	200	50	100	150	200	50	100	150	200	50	100	150	200	50	100	150	200	50	100	
M	0	0	0	0	0	1	1	1	1	2	2	2	2	3	3	3	3	4	4	4	4	5	5	5	5	6	6	6	6	7	7	
N	8	10	10	10	10	12	12	12	12	14	14	14	14	16	16	16	16	18	18	18	18	20	20	20	20	22	22	22	22	24	24	
KG	7.3	7.8	8.3	8.8	9.3	9.8	10.3	10.8	11.3	11.8	12.3	12.8	13.3	13.8	14.3	14.8	15.3	15.8	16.3	16.8	17.3	17.8	18.3	18.8	19.3	19.8	20.3	20.8	21.3	21.8	22.3	
有效行程	1600	1650	1700	1750	1800	1850	1900	1950	2000	2050	2100	2150	2200	2250	2300	2350	2400	2450	2500	2550	2600	2650	2700	2750	2800	2850	2900	2950	3000	3050	3100	
L	1938	1988	2038	2088	2138	2188	2238	2288	2338	2388	2438	2488	2538	2588	2638	2688	2738	2788	2838	2888	2938	2988	3038	3088	3138	3188	3238	3288	3338	3388	3438	
A	150	200	50	100	150	200	50	100	150	200	50	100	150	200	50	100	150	200	50	100	150	200	50	100	150	200	50	100	150	200	50	
M	7	7	8	8	8	8	9	9	9	9	10	10	10	10	11	11	11	11	12	12	12	12	13	13	13	13	14	14	14	14	15	
N	24	24	26	26	26	26	28	28	28	28	30	30	30	30	32	32	32	32	34	34	34	34	34	36	36	36	36	38	38	38	38	40
KG	22.8	23.3	23.8	24.3	24.8	25.3	25.8	26.3	26.8	27.3	27.8	28.3	28.8	29.3	29.8	30.3	30.8	31.3	31.8	32.3	32.8	33.3	33.8	34.3	34.8	35.3	35.8	36.3	36.8	37.3	37.8	

注：以上不含电机重量。
Note: Not including motor weight.

电机右下折-RD Motor Folds Down on the Right

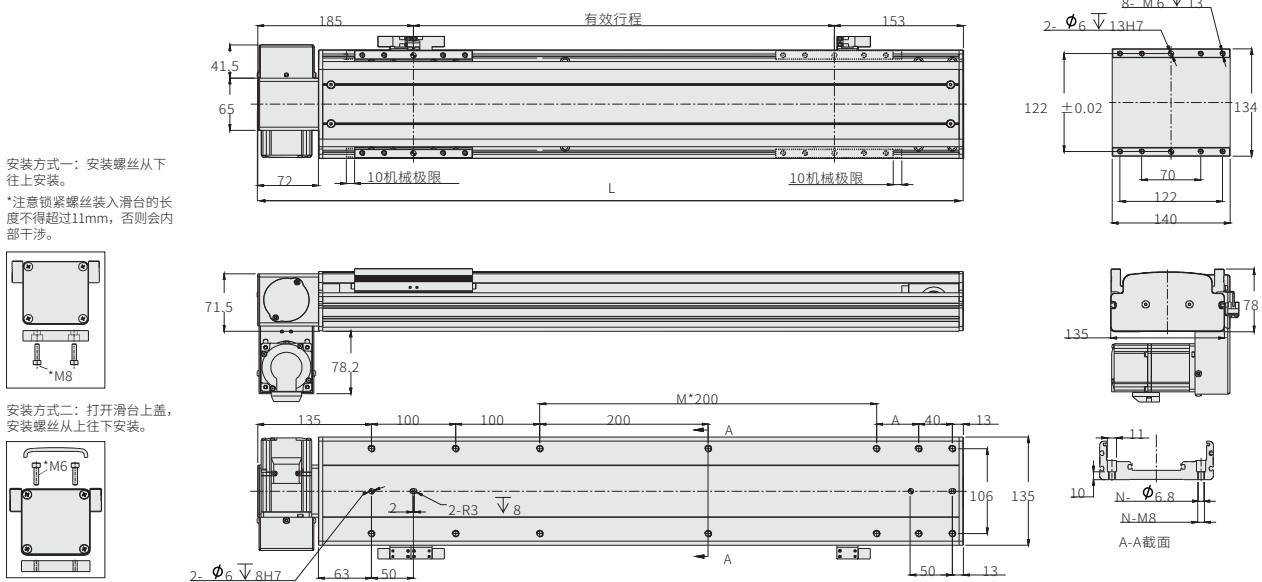

安装方式一：安装螺丝从下往上安装。
*注意锁紧螺丝装入滑台的长度不得超过11mm，否则会影响内部干涉。

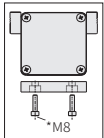

安装方式二：打开滑台上盖，安装螺丝从上往下安装。

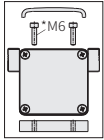

有效行程	50	100	150	200	250	300	350	400	450	500	550	600	650	700	750	800	850	900	950	1000	1050	1100	1150	1200	1250	1300	1350	1400	1450	1500	1550	
L	388	438	488	538	588	638	688	738	788	838	888	938	988	1038	1088	1138	1188	1238	1288	1338	1388	1438	1488	1538	1588	1638	1688	1738	1788	1838	1888	
A	0	50	100	150	200	50	100	150	200	50	100	150	200	50	100	150	200	50	100	150	200	50	100	150	200	50	100	150	200	50	100	
M	0	0	0	0	0	1	1	1	1	2	2	2	2	3	3	3	3	4	4	4	4	5	5	5	5	6	6	6	6	7	7	
N	8	10	10	10	10	12	12	12	12	14	14	14	14	16	16	16	16	18	18	18	18	20	20	20	20	22	22	22	22	24	24	
KG	7.3	7.8	8.3	8.8	9.3	9.8	10.3	10.8	11.3	11.8	12.3	12.8	13.3	13.8	14.3	14.8	15.3	15.8	16.3	16.8	17.3	17.8	18.3	18.8	19.3	19.8	20.3	20.8	21.3	21.8	22.3	
有效行程	1600	1650	1700	1750	1800	1850	1900	1950	2000	2050	2100	2150	2200	2250	2300	2350	2400	2450	2500	2550	2600	2650	2700	2750	2800	2850	2900	2950	3000	3050	3100	
L	1938	1988	2038	2088	2138	2188	2238	2288	2338	2388	2438	2488	2538	2588	2638	2688	2738	2788	2838	2888	2938	2988	3038	3088	3138	3188	3238	3288	3338	3388	3438	
A	150	200	50	100	150	200	50	100	150	200	50	100	150	200	50	100	150	200	50	100	150	200	50	100	150	200	50	100	150	200	50	
M	7	7	8	8	8	8	9	9	9	9	10	10	10	10	11	11	11	11	12	12	12	12	13	13	13	13	14	14	14	14	15	
N	24	24	26	26	26	26	28	28	28	28	30	30	30	30	32	32	32	32	34	34	34	34	34	36	36	36	36	38	38	38	38	40
KG	22.8	23.3	23.8	24.3	24.8	25.3	25.8	26.3	26.8	27.3	27.8	28.3	28.8	29.3	29.8	30.3	30.8	31.3	31.8	32.3	32.8	33.3	33.8	34.3	34.8	35.3	35.8	36.3	36.8	37.3	37.8	

注：以上不含电机重量。
Note: Not including motor weight.