

同步带模组 (半密封) -HB22M

Timing Belt Module (semi-sealed)

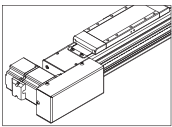

电机安装方式 How the Motor is Installed



电机左折-L
Motor left side

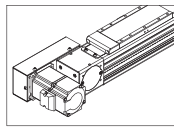

电机右折-R
Motor right side

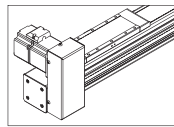

电机左上折-LU
Motor folds on the upper left

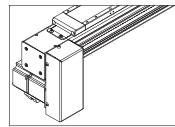

电机左下折-LD
Motor folds down left

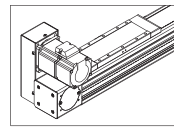

电机右上折-RU
Motor folds up on the right

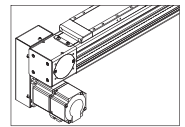

电机右下折-RD
Motor folds down on the right

型号表示方式 Guide for Model Selection

Z-Mod-HB22M-50-100-L-75SEB-N3-FXXX-01

HB22M	50	100	L	75SE	B	N3	FXXX-01
本体型号 Base Model	导程 Lead 50: 50mm *导程: 电机旋转一圈, 滑台移动的直线距离。	行程 Stroke 100-4500mm	电机方式 Motor way L: 左折 R: 右折 LU: 左上折 LD: 左下折 RU: 右上折 RD: 右下折	电机功率 Motor power 75SE: 750W伺服	刹车 Brakes 无: 无电机 B: 一体式电机 (带刹车) M: 一体式电机	感应开关数量 Sensor quantity N3: 3个NPN传感器 N2: 2个NPN传感器 N1: 1个NPN传感器 P3: 3个PNP传感器 P2: 2个PNP传感器 P1: 1个PNP传感器 N: 无	特殊定制 Customer number F: 非标准定制选项, 若为标准品, 则为空 XXX: 客户标号 01: 版本号

基本参数 Parameters

电机转速 Motor speed(rpm/min)	500	1000	1500	2000	2500	3000
最高速度 Maximum payload(mm/s)	416	833	1250	1600	2100	2500
最大负载 Rated load(kg)(水平使用)	70	70	55	43	35	31
重复位置精度 Repeatability(mm)	±0.04					
*导程 Lead(mm)	50					
额定推力 Rated thrust(n)	300					
行程范围 Range of travel(mm)	100-4500MM/50行程递增					
电机功率 Motor output(w)	750					
皮带宽度 Synchro band width(mm)	50					
导轨规格 Guide specification	W23XH22-2支					
感应器 Sensor	EE-SX674(NPN)					

- *导程: 电机旋转一圈, 滑台移动的直线距离。
*Guide: the rotation of the motor and the straight distance of the sliding table.
- *电机加减速时间为0.4S。
*Motor speed is 0.4S.
- *如有特殊定制请先与技术人员联系。
If you have special customization, please contact a technician first.

安装示意图 Installation Diagram

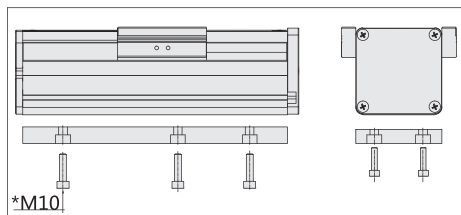

安装方式一: 安装螺丝从下往上安装。
Installation method 1: The screws are installed from bottom to bottom.

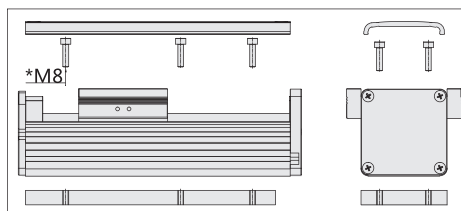

安装方式二: 打开滑台上盖, 安装螺丝从上往下安装。
Installation method 2: Open the sliding table cover and install the screws from top to bottom.

传感器接线图 Sensor Wiring Diagram

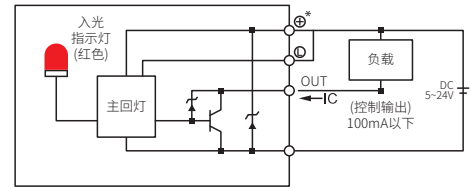

负载与速度 Load and Speed

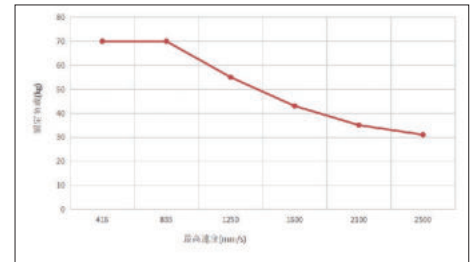

静态力矩表 Static Moment

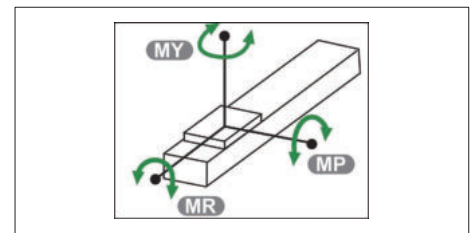

MY	2050 (N.M)
MP	2050 (N.M)
MR	1810 (N.M)

电机左折-L Motor Left Side

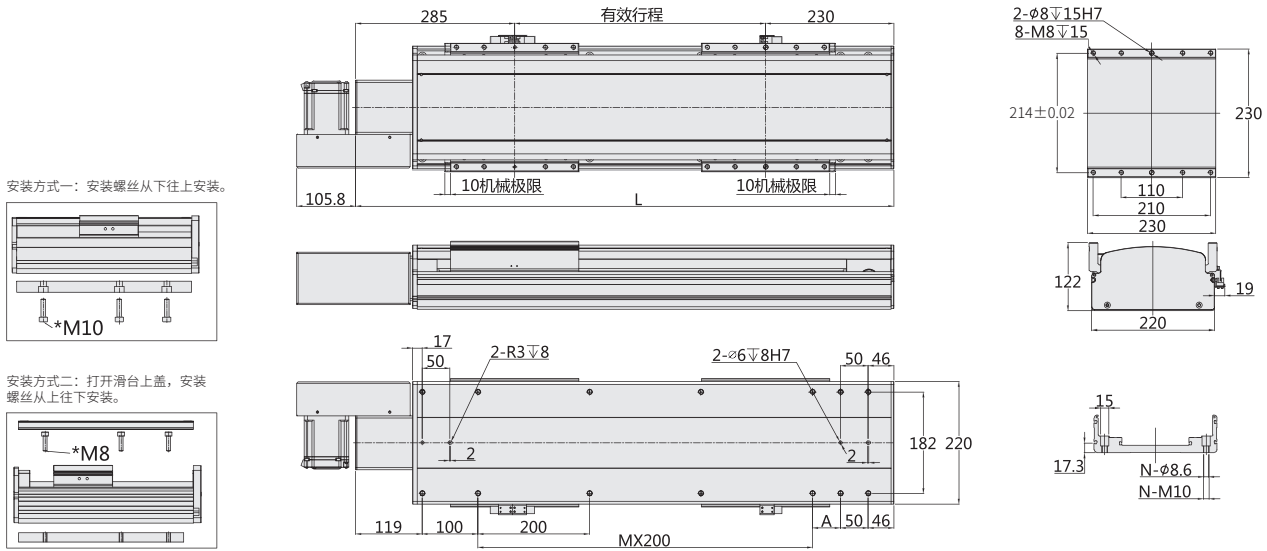

有效行程	300	350	400	450	500	550	600	650	700	750	800	850	900	950	1000	1050	1100	1150	1200	1250	1300	1350	1400	1450	1500	1550	1600	1650
L	815	865	915	965	1015	1065	1115	1165	1215	1265	1315	1365	1415	1465	1515	1565	1615	1665	1715	1765	1815	1865	1915	1965	2015	2065	2115	2165
A	100	150	200	50	100	150	200	50	100	150	200	50	100	150	200	50	100	150	200	50	100	150	200	50	100	150	200	50
M	2	2	2	3	3	3	3	3	4	4	4	4	5	5	5	5	6	6	6	6	7	7	7	7	8	8	8	9
N	12	12	12	14	14	14	14	14	16	16	16	16	18	18	18	18	20	20	20	20	22	22	22	22	24	24	24	26
KG	34.8	36	37.2	38.4	39.6	40.8	42	43.2	44.4	45.6	46.8	48	49.2	51.4	52.6	53.8	55	56.2	57.4	58.6	59.8	61	62.2	63.4	64.6	65.8	67	68.2
有效行程	1700	1750	1800	1850	1900	1950	2000	2100	2200	2300	2400	2500	2600	2700	2800	2900	3000	3100	3200	3300	3400	3500	3600	3700	3800	3900	4000	4100
L	2215	2265	2315	2365	2415	2465	2515	2615	2715	2815	2915	3015	3115	3215	3315	3415	3515	3615	3715	3815	3915	4015	4115	4215	4315	4415	4515	4615
A	100	150	200	50	100	150	200	100	200	100	200	100	200	100	200	100	200	100	200	100	200	100	200	100	200	100	200	100
M	9	9	9	10	10	10	10	11	11	12	12	13	13	14	14	15	15	16	16	17	17	18	18	19	19	20	20	21
N	26	26	26	28	28	28	28	30	30	32	32	34	34	36	36	38	38	40	40	42	42	44	44	46	46	48	48	50
KG	69.4	70.6	71.8	73.0	74.2	75.4	76.6	79.0	81.4	83.8	86.2	88.6	91.0	93.4	95.8	98.2	100.6	103.0	105.4	107.8	110.2	112.6	115.0	117.4	119.8	122.2	124.6	127.0

注：以上不含电机重量。
Note: Not including motor weight.

电机右折-R Motor Right Side

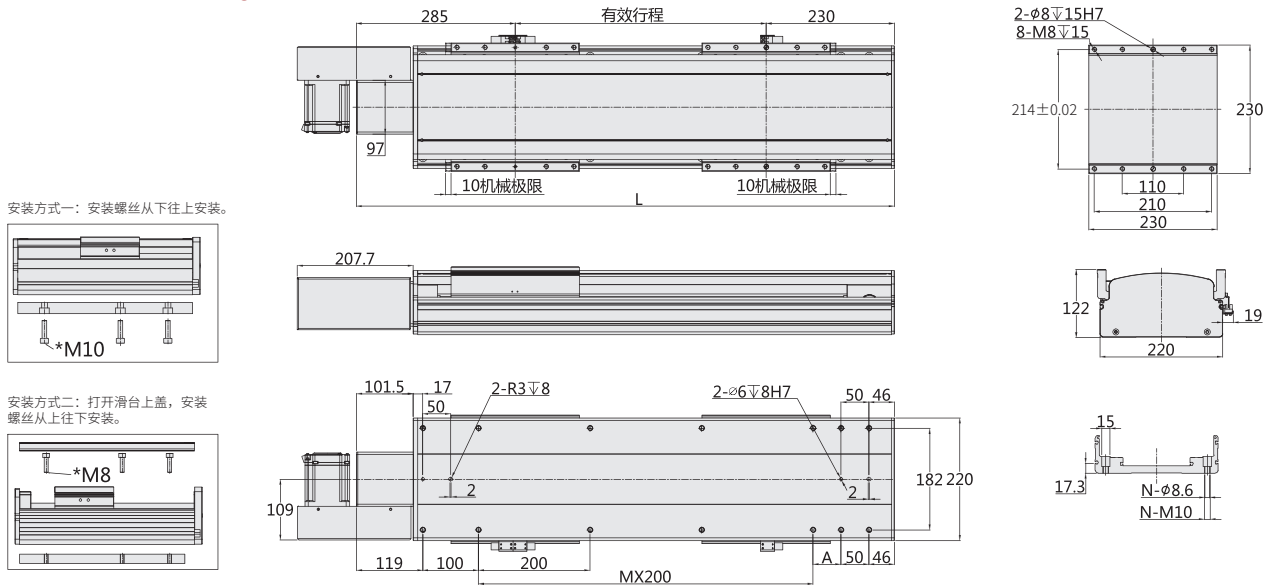

有效行程	300	350	400	450	500	550	600	650	700	750	800	850	900	950	1000	1050	1100	1150	1200	1250	1300	1350	1400	1450	1500	1550	1600	1650
L	815	865	915	965	1015	1065	1115	1165	1215	1265	1315	1365	1415	1465	1515	1565	1615	1665	1715	1765	1815	1865	1915	1965	2015	2065	2115	2165
A	100	150	200	50	100	150	200	50	100	150	200	50	100	150	200	50	100	150	200	50	100	150	200	50	100	150	200	50
M	2	2	2	3	3	3	3	3	4	4	4	4	5	5	5	5	6	6	6	6	7	7	7	7	8	8	8	9
N	12	12	12	14	14	14	14	14	16	16	16	16	18	18	18	18	20	20	20	20	22	22	22	22	24	24	24	26
KG	34.8	36	37.2	38.4	39.6	40.8	42	43.2	44.4	45.6	46.8	48	49.2	51.4	52.6	53.8	55	56.2	57.4	58.6	59.8	61	62.2	63.4	64.6	65.8	67	68.2
有效行程	1700	1750	1800	1850	1900	1950	2000	2100	2200	2300	2400	2500	2600	2700	2800	2900	3000	3100	3200	3300	3400	3500	3600	3700	3800	3900	4000	4100
L	2215	2265	2315	2365	2415	2465	2515	2615	2715	2815	2915	3015	3115	3215	3315	3415	3515	3615	3715	3815	3915	4015	4115	4215	4315	4415	4515	4615
A	100	150	200	50	100	150	200	100	200	100	200	100	200	100	200	100	200	100	200	100	200	100	200	100	200	100	200	100
M	9	9	9	10	10	10	10	11	11	12	12	13	13	14	14	15	15	16	16	17	17	18	18	19	19	20	20	21
N	26	26	26	28	28	28	28	30	30	32	32	34	34	36	36	38	38	40	40	42	42	44	44	46	46	48	48	50
KG	69.4	70.6	71.8	73.0	74.2	75.4	76.6	79.0	81.4	83.8	86.2	88.6	91.0	93.4	95.8	98.2	100.6	103.0	105.4	107.8	110.2	112.6	115.0	117.4	119.8	122.2	124.6	127.0

注：以上不含电机重量。
Note: Not including motor weight.

电机左上折-LU Motor Folds on the Upper Left

安装方式一：安装螺丝从下往上安装。

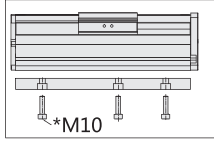

安装方式二：打开滑台上盖，安装螺丝从上往下安装。

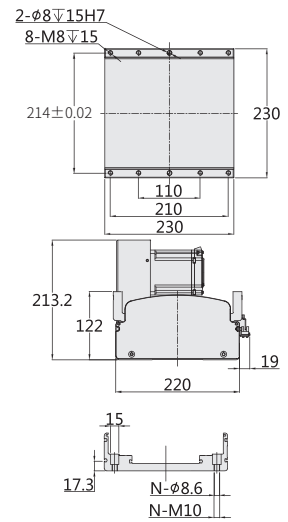
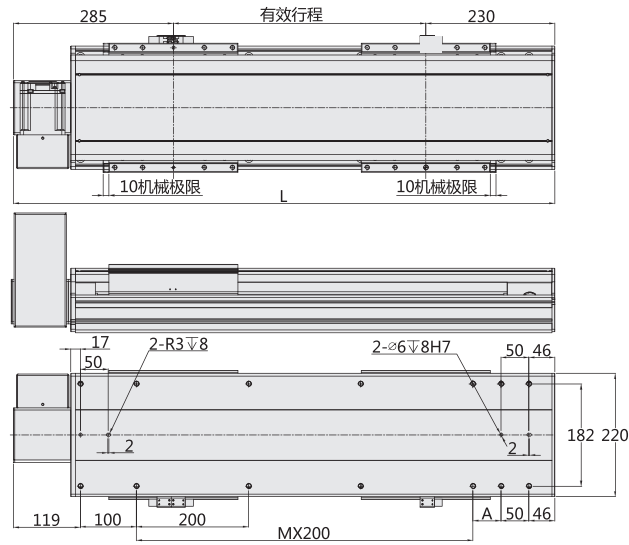
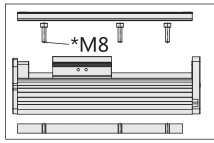

有效行程	300	350	400	450	500	550	600	650	700	750	800	850	900	950	1000	1050	1100	1150	1200	1250	1300	1350	1400	1450	1500	1550	1600	1650
L	815	865	915	965	1015	1065	1115	1165	1215	1265	1315	1365	1415	1465	1515	1565	1615	1665	1715	1765	1815	1865	1915	1965	2015	2065	2115	2165
A	100	150	200	50	100	150	200	50	100	150	200	50	100	150	200	50	100	150	200	50	100	150	200	50	100	150	200	50
M	2	2	2	3	3	3	3	4	4	4	4	5	5	5	5	6	6	6	6	7	7	7	7	8	8	8	8	9
N	12	12	12	14	14	14	14	16	16	16	16	18	18	18	18	20	20	20	20	22	22	22	22	24	24	24	24	26
KG	34.8	36	37.2	38.4	39.6	40.8	42	43.2	44.4	45.6	46.8	48	49.2	51.4	52.6	53.8	55	56.2	57.4	58.6	59.8	61	62.2	63.4	64.6	65.8	67	68.2
有效行程	1700	1750	1800	1850	1900	1950	2000	2100	2200	2300	2400	2500	2600	2700	2800	2900	3000	3100	3200	3300	3400	3500	3600	3700	3800	3900	4000	4100
L	2215	2265	2315	2365	2415	2465	2515	2615	2715	2815	2915	3015	3115	3215	3315	3415	3515	3615	3715	3815	3915	4015	4115	4215	4315	4415	4515	4615
A	100	150	200	50	100	150	200	100	200	100	200	100	200	100	200	100	200	100	200	100	200	100	200	100	200	100	200	100
M	9	9	9	10	10	10	10	11	11	12	12	13	13	14	14	15	15	16	16	17	17	17	18	18	19	19	20	21
N	26	26	26	28	28	28	28	30	30	32	32	34	34	36	36	38	38	40	40	42	42	44	44	46	46	48	48	50
KG	69.4	70.6	71.8	73.0	74.2	75.4	76.6	79.0	81.4	83.8	86.2	88.6	91.0	93.4	95.8	98.2	100.6	103.0	105.4	107.8	110.2	112.6	115.0	117.4	119.8	122.2	124.6	127.0

注：以上不含电机重量。
Note: Not including motor weight.

电机左下折-LD Motor Folds Down Deft

安装方式一：安装螺丝从下往上安装。

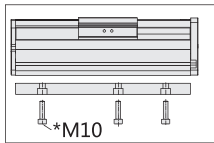

安装方式二：打开滑台上盖，安装螺丝从上往下安装。

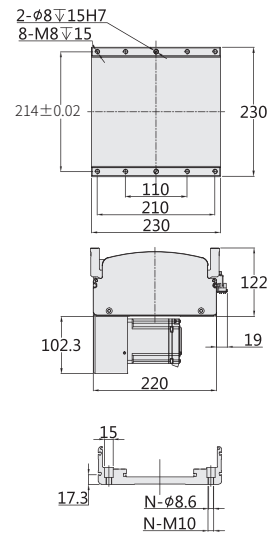
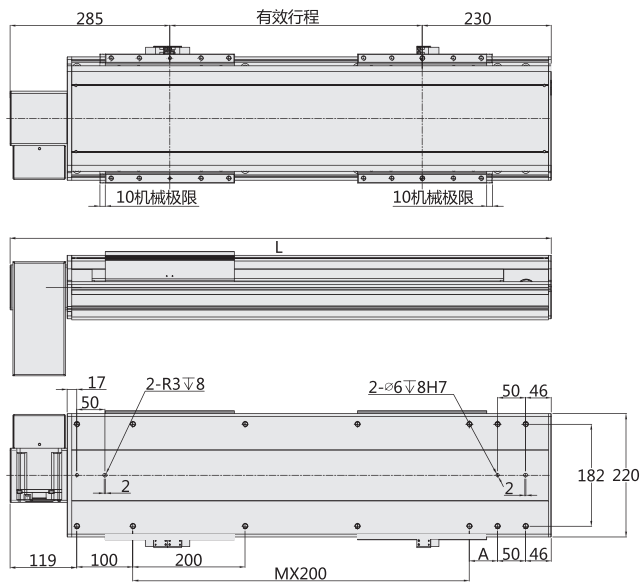
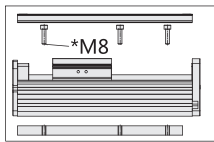

有效行程	300	350	400	450	500	550	600	650	700	750	800	850	900	950	1000	1050	1100	1150	1200	1250	1300	1350	1400	1450	1500	1550	1600	1650
L	815	865	915	965	1015	1065	1115	1165	1215	1265	1315	1365	1415	1465	1515	1565	1615	1665	1715	1765	1815	1865	1915	1965	2015	2065	2115	2165
A	100	150	200	50	100	150	200	50	100	150	200	50	100	150	200	50	100	150	200	50	100	150	200	50	100	150	200	50
M	2	2	2	3	3	3	3	4	4	4	4	5	5	5	5	6	6	6	6	7	7	7	7	8	8	8	8	9
N	12	12	12	14	14	14	14	16	16	16	16	18	18	18	18	20	20	20	20	22	22	22	22	24	24	24	24	26
KG	34.8	36	37.2	38.4	39.6	40.8	42	43.2	44.4	45.6	46.8	48	49.2	51.4	52.6	53.8	55	56.2	57.4	58.6	59.8	61	62.2	63.4	64.6	65.8	67	68.2
有效行程	1700	1750	1800	1850	1900	1950	2000	2100	2200	2300	2400	2500	2600	2700	2800	2900	3000	3100	3200	3300	3400	3500	3600	3700	3800	3900	4000	4100
L	2215	2265	2315	2365	2415	2465	2515	2615	2715	2815	2915	3015	3115	3215	3315	3415	3515	3615	3715	3815	3915	4015	4115	4215	4315	4415	4515	4615
A	100	150	200	50	100	150	200	100	200	100	200	100	200	100	200	100	200	100	200	100	200	100	200	100	200	100	200	100
M	9	9	9	10	10	10	10	11	11	12	12	13	13	14	14	15	15	16	16	17	17	17	18	18	19	19	20	21
N	26	26	26	28	28	28	28	30	30	32	32	34	34	36	36	38	38	40	40	42	42	44	44	46	46	48	48	50
KG	69.4	70.6	71.8	73.0	74.2	75.4	76.6	79.0	81.4	83.8	86.2	88.6	91.0	93.4	95.8	98.2	100.6	103.0	105.4	107.8	110.2	112.6	115.0	117.4	119.8	122.2	124.6	127.0

注：以上不含电机重量。
Note: Not including motor weight.

电机右上折-RU Motor Folds up on the Right

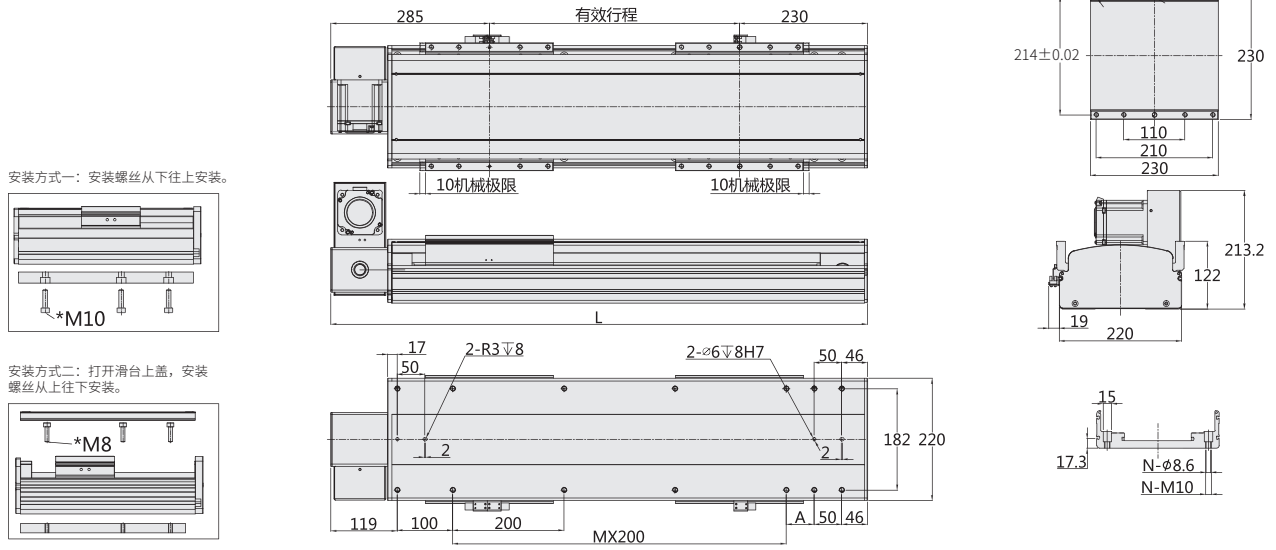

有效行程	300	350	400	450	500	550	600	650	700	750	800	850	900	950	1000	1050	1100	1150	1200	1250	1300	1350	1400	1450	1500	1550	1600	1650
L	815	865	915	965	1015	1065	1115	1165	1215	1265	1315	1365	1415	1465	1515	1565	1615	1665	1715	1765	1815	1865	1915	1965	2015	2065	2115	2165
A	100	150	200	50	100	150	200	50	100	150	200	50	100	150	200	50	100	150	200	50	100	150	200	50	100	150	200	50
M	2	2	2	3	3	3	3	4	4	4	4	5	5	5	5	6	6	6	6	7	7	7	7	8	8	8	8	9
N	12	12	12	14	14	14	14	16	16	16	16	18	18	18	18	20	20	20	20	22	22	22	22	24	24	24	24	26
KG	34.8	36	37.2	38.4	39.6	40.8	42	43.2	44.4	45.6	46.8	48	49.2	51.4	52.6	53.8	55	56.2	57.4	58.6	59.8	61	62.2	63.4	64.6	65.8	67	68.2
有效行程	1700	1750	1800	1850	1900	1950	2000	2100	2200	2300	2400	2500	2600	2700	2800	2900	3000	3100	3200	3300	3400	3500	3600	3700	3800	3900	4000	4100
L	2215	2265	2315	2365	2415	2465	2515	2615	2715	2815	2915	3015	3115	3215	3315	3415	3515	3615	3715	3815	3915	4015	4115	4215	4315	4415	4515	4615
A	100	150	200	50	100	150	200	100	200	100	200	100	200	100	200	100	200	100	200	100	200	100	200	100	200	100	200	100
M	9	9	9	10	10	10	10	11	11	12	12	13	13	14	14	15	15	16	16	17	17	18	18	19	19	20	20	21
N	26	26	26	28	28	28	28	30	30	32	32	34	34	36	36	38	38	40	40	42	42	44	44	46	46	48	48	50
KG	69.4	70.6	71.8	73.0	74.2	75.4	76.6	79.0	81.4	83.8	86.2	88.6	91.0	93.4	95.8	98.2	100.6	103.0	105.4	107.8	110.2	112.6	115.0	117.4	119.8	122.2	124.6	127.0

注：以上不含电机重量。
Note: Not including motor weight.

电机右下折-RD Motor Folds Down on the Right

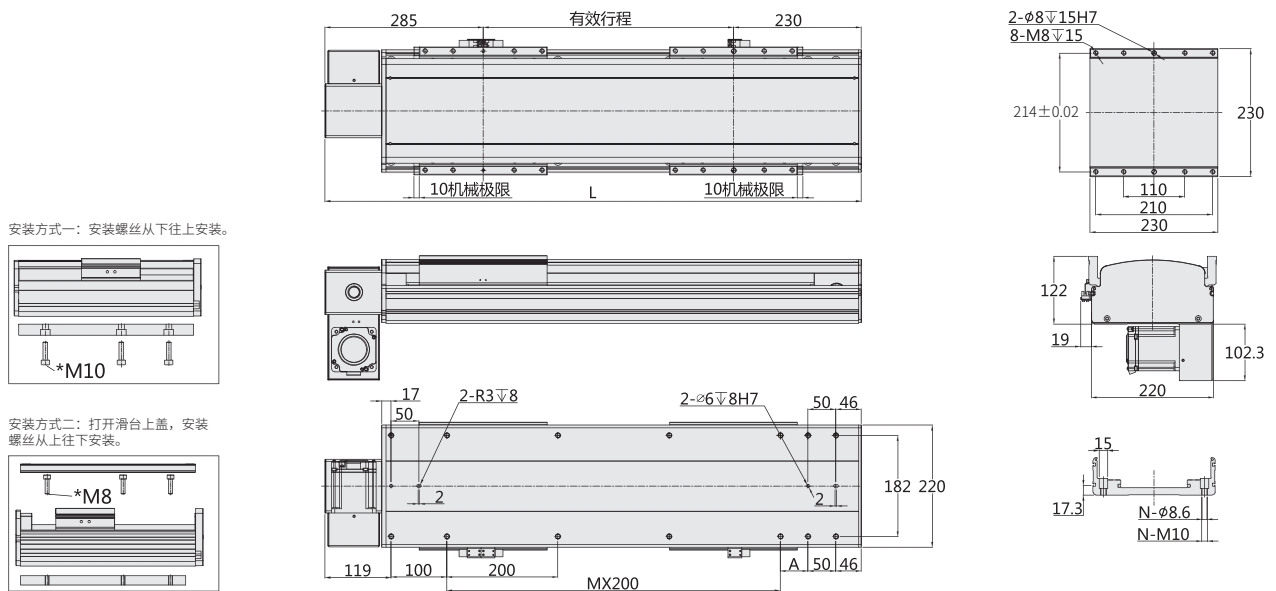

有效行程	300	350	400	450	500	550	600	650	700	750	800	850	900	950	1000	1050	1100	1150	1200	1250	1300	1350	1400	1450	1500	1550	1600	1650
L	815	865	915	965	1015	1065	1115	1165	1215	1265	1315	1365	1415	1465	1515	1565	1615	1665	1715	1765	1815	1865	1915	1965	2015	2065	2115	2165
A	100	150	200	50	100	150	200	50	100	150	200	50	100	150	200	50	100	150	200	50	100	150	200	50	100	150	200	50
M	2	2	2	3	3	3	3	4	4	4	4	5	5	5	5	6	6	6	6	7	7	7	7	8	8	8	8	9
N	12	12	12	14	14	14	14	16	16	16	16	18	18	18	18	20	20	20	20	22	22	22	22	24	24	24	24	26
KG	34.8	36	37.2	38.4	39.6	40.8	42	43.2	44.4	45.6	46.8	48	49.2	51.4	52.6	53.8	55	56.2	57.4	58.6	59.8	61	62.2	63.4	64.6	65.8	67	68.2
有效行程	1700	1750	1800	1850	1900	1950	2000	2100	2200	2300	2400	2500	2600	2700	2800	2900	3000	3100	3200	3300	3400	3500	3600	3700	3800	3900	4000	4100
L	2215	2265	2315	2365	2415	2465	2515	2615	2715	2815	2915	3015	3115	3215	3315	3415	3515	3615	3715	3815	3915	4015	4115	4215	4315	4415	4515	4615
A	100	150	200	50	100	150	200	100	200	100	200	100	200	100	200	100	200	100	200	100	200	100	200	100	200	100	200	100
M	9	9	9	10	10	10	10	11	11	12	12	13	13	14	14	15	15	16	16	17	17	18	18	19	19	20	20	21
N	26	26	26	28	28	28	28	30	30	32	32	34	34	36	36	38	38	40	40	42	42	44	44	46	46	48	48	50
KG	69.4	70.6	71.8	73.0	74.2	75.4	76.6	79.0	81.4	83.8	86.2	88.6	91.0	93.4	95.8	98.2	100.6	103.0	105.4	107.8	110.2	112.6	115.0	117.4	119.8	122.2	124.6	127.0

注：以上不含电机重量。
Note: Not including motor weight.