

电机左折-L Motor Left Side

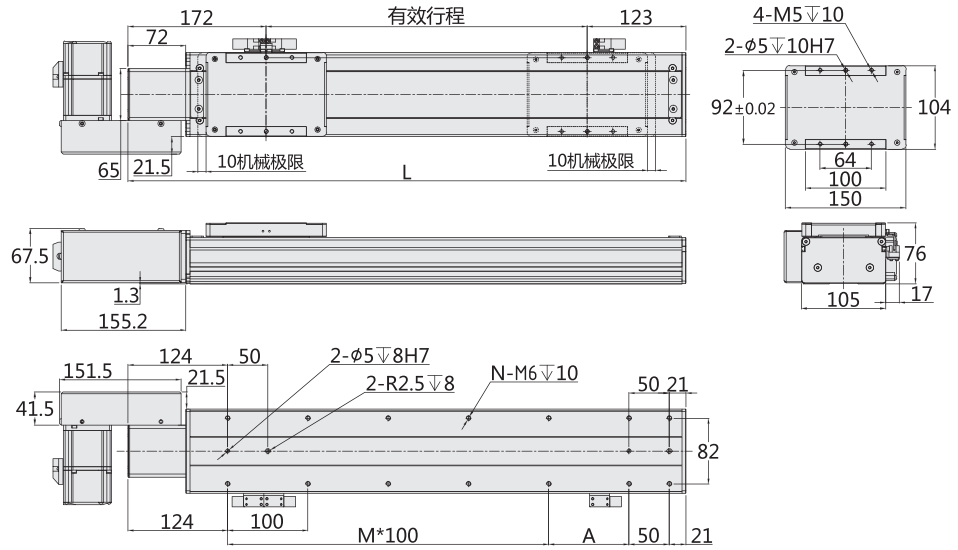

安装方式: 安装螺丝从下往上安装
*注意锁紧螺丝装入滑台的长度不得超过11mm, 否则会内部干涉。

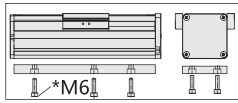

有效行程	50	100	150	200	250	300	350	400	450	500	550	600	650	700	750	800	850	900	950	1000	1050	1100	1150	1200	1250	1300
L	345	395	445	495	545	595	645	695	745	795	845	895	945	995	1045	1095	1145	1195	1245	1295	1345	1395	1445	1495	1545	1595
A	50	100	50	100	50	100	50	100	50	100	50	100	50	100	50	100	50	100	50	100	50	100	50	100	50	100
M	1	1	2	2	3	3	4	4	5	5	6	6	7	7	8	8	9	9	10	10	11	11	12	12	13	13
N	8	8	10	10	12	12	14	14	16	16	18	18	20	20	22	22	24	24	26	26	28	28	30	30	32	32
KG	6.4	6.8	7.2	7.7	8.1	8.5	9.0	9.4	9.8	10.2	10.7	11.1	11.5	12.0	12.4	12.8	13.3	13.7	14.1	14.5	15.0	15.4	15.8	16.3	16.7	17.1
有效行程	1350	1400	1450	1500	1550	1600	1650	1700	1750	1800	1850	1900	1950	2000	2050	2100	2150	2200	2250	2300	2350	2400	2450	2500	2550	2600
L	1645	1695	1745	1795	1845	1895	1945	1995	2045	2095	2145	2195	2245	2295	2345	2395	2445	2495	2545	2595	2645	2695	2745	2795	2845	2895
A	50	100	50	100	50	100	50	100	50	100	50	100	50	100	50	100	50	100	50	100	50	100	50	100	50	100
M	14	14	15	15	16	16	17	17	18	18	19	19	20	20	21	21	22	22	23	23	24	24	25	25	26	26
N	34	34	36	36	38	38	40	40	42	42	44	44	46	46	48	48	50	50	52	52	54	54	56	56	58	58
KG	17.5	18.0	18.4	18.8	19.3	19.7	20.1	20.6	21.0	21.4	21.8	22.3	22.7	23.1	23.6	24.0	24.4	24.8	25.3	25.7	26.1	26.6	27.0	27.4	27.9	28.3

注: 以上不含电机重量。
Note: Not including motor weight.

电机右折-R Motor Right Side

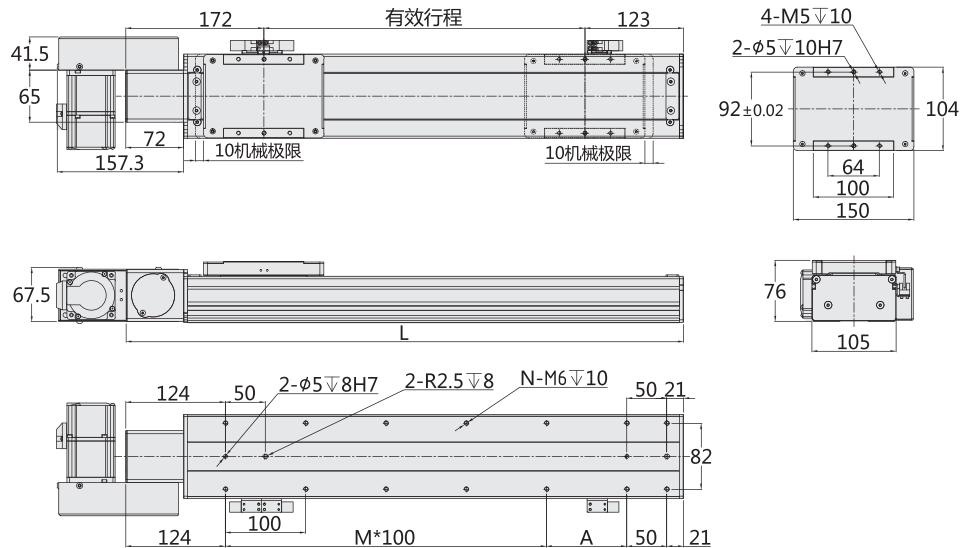

安装方式: 安装螺丝从下往上安装
*注意锁紧螺丝装入滑台的长度不得超过11mm, 否则会内部干涉。

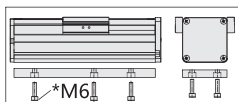

有效行程	50	100	150	200	250	300	350	400	450	500	550	600	650	700	750	800	850	900	950	1000	1050	1100	1150	1200	1250	1300
L	345	395	445	495	545	595	645	695	745	795	845	895	945	995	1045	1095	1145	1195	1245	1295	1345	1395	1445	1495	1545	1595
A	50	100	50	100	50	100	50	100	50	100	50	100	50	100	50	100	50	100	50	100	50	100	50	100	50	100
M	1	1	2	2	3	3	4	4	5	5	6	6	7	7	8	8	9	9	10	10	11	11	12	12	13	13
N	8	8	10	10	12	12	14	14	16	16	18	18	20	20	22	22	24	24	26	26	28	28	30	30	32	32
KG	6.4	6.8	7.2	7.7	8.1	8.5	9.0	9.4	9.8	10.2	10.7	11.1	11.5	12.0	12.4	12.8	13.3	13.7	14.1	14.5	15.0	15.4	15.8	16.3	16.7	17.1
有效行程	1350	1400	1450	1500	1550	1600	1650	1700	1750	1800	1850	1900	1950	2000	2050	2100	2150	2200	2250	2300	2350	2400	2450	2500	2550	2600
L	1645	1695	1745	1795	1845	1895	1945	1995	2045	2095	2145	2195	2245	2295	2345	2395	2445	2495	2545	2595	2645	2695	2745	2795	2845	2895
A	50	100	50	100	50	100	50	100	50	100	50	100	50	100	50	100	50	100	50	100	50	100	50	100	50	100
M	14	14	15	15	16	16	17	17	18	18	19	19	20	20	21	21	22	22	23	23	24	24	25	25	26	26
N	34	34	36	36	38	38	40	40	42	42	44	44	46	46	48	48	50	50	52	52	54	54	56	56	58	58
KG	17.5	18.0	18.4	18.8	19.3	19.7	20.1	20.6	21.0	21.4	21.8	22.3	22.7	23.1	23.6	24.0	24.4	24.8	25.3	25.7	26.1	26.6	27.0	27.4	27.9	28.3

注: 以上不含电机重量。
Note: Not including motor weight.



电机左上折-LU Motor Folds on the Upper Left

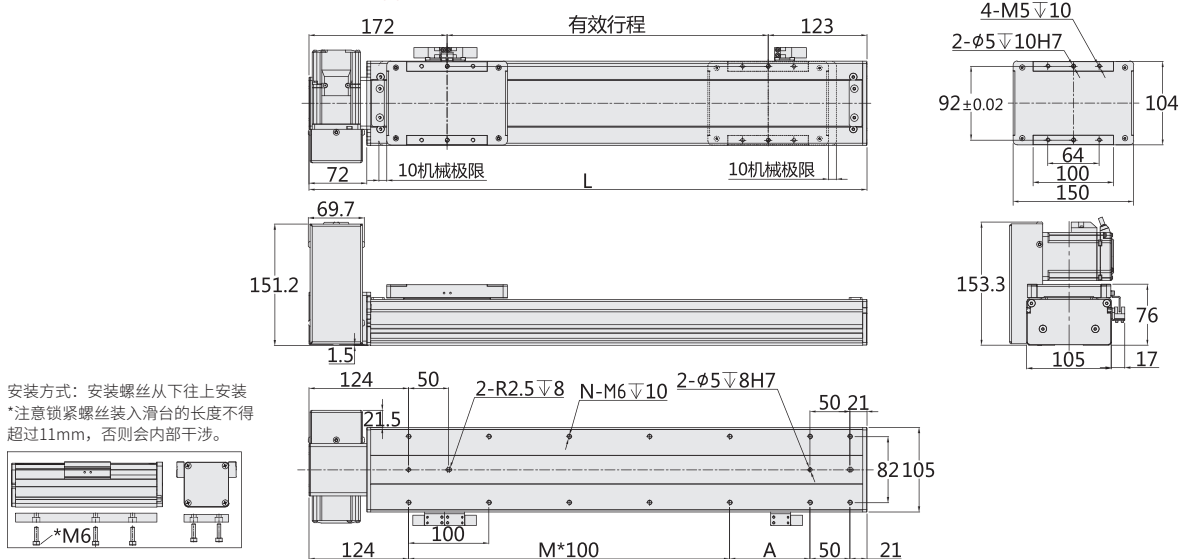

安装方式：安装螺丝从下往上安装
*注意锁紧螺丝装入滑台的长度不得超过11mm，否则会内部干涉。

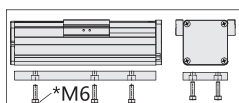

有效行程	50	100	150	200	250	300	350	400	450	500	550	600	650	700	750	800	850	900	950	1000	1050	1100	1150	1200	1250	1300
L	345	395	445	495	545	595	645	695	745	795	845	895	945	995	1045	1095	1145	1195	1245	1295	1345	1395	1445	1495	1545	1595
A	50	100	50	100	50	100	50	100	50	100	50	100	50	100	50	100	50	100	50	100	50	100	50	100	50	100
M	1	1	2	2	3	3	4	4	5	5	6	6	7	7	8	8	9	9	10	10	11	11	12	12	13	13
N	8	8	10	10	12	12	14	14	16	16	18	18	20	20	22	22	24	24	26	26	28	28	30	30	32	32
KG	6.4	6.8	7.2	7.7	8.1	8.5	9.0	9.4	9.8	10.2	10.7	11.1	11.5	12.0	12.4	12.8	13.3	13.7	14.1	14.5	15.0	15.4	15.8	16.3	16.7	17.1
有效行程	1350	1400	1450	1500	1550	1600	1650	1700	1750	1800	1850	1900	1950	2000	2050	2100	2150	2200	2250	2300	2350	2400	2450	2500	2550	2600
L	1645	1695	1745	1795	1845	1895	1945	1995	2045	2095	2145	2195	2245	2295	2345	2395	2445	2495	2545	2595	2645	2695	2745	2795	2845	2895
A	50	100	50	100	50	100	50	100	50	100	50	100	50	100	50	100	50	100	50	100	50	100	50	100	50	100
M	14	14	15	15	16	16	17	17	18	18	19	19	20	20	21	21	22	22	23	23	24	24	25	25	26	26
N	34	34	36	36	38	38	40	40	42	42	44	44	46	46	48	48	50	50	52	52	54	54	56	56	58	58
KG	17.5	18.0	18.4	18.8	19.3	19.7	20.1	20.6	21.0	21.4	21.8	22.3	22.7	23.1	23.6	24.0	24.4	24.8	25.3	25.7	26.1	26.6	27.0	27.4	27.9	28.3

注：以上不含电机重量。
Note: Not including motor weight.

电机左下折-LD Motor Folds Down Deft

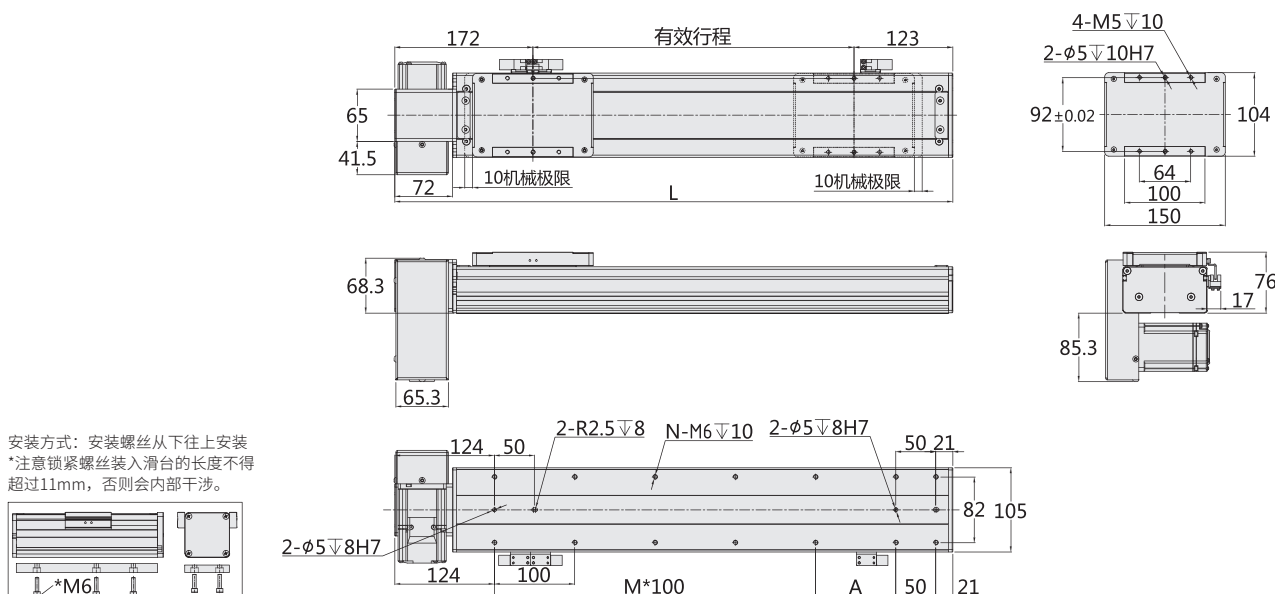

安装方式：安装螺丝从下往上安装
*注意锁紧螺丝装入滑台的长度不得超过11mm，否则会内部干涉。

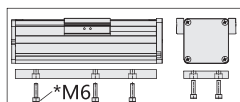

有效行程	50	100	150	200	250	300	350	400	450	500	550	600	650	700	750	800	850	900	950	1000	1050	1100	1150	1200	1250	1300
L	345	395	445	495	545	595	645	695	745	795	845	895	945	995	1045	1095	1145	1195	1245	1295	1345	1395	1445	1495	1545	1595
A	50	100	50	100	50	100	50	100	50	100	50	100	50	100	50	100	50	100	50	100	50	100	50	100	50	100
M	1	1	2	2	3	3	4	4	5	5	6	6	7	7	8	8	9	9	10	10	11	11	12	12	13	13
N	8	8	10	10	12	12	14	14	16	16	18	18	20	20	22	22	24	24	26	26	28	28	30	30	32	32
KG	6.4	6.8	7.2	7.7	8.1	8.5	9.0	9.4	9.8	10.2	10.7	11.1	11.5	12.0	12.4	12.8	13.3	13.7	14.1	14.5	15.0	15.4	15.8	16.3	16.7	17.1
有效行程	1350	1400	1450	1500	1550	1600	1650	1700	1750	1800	1850	1900	1950	2000	2050	2100	2150	2200	2250	2300	2350	2400	2450	2500	2550	2600
L	1645	1695	1745	1795	1845	1895	1945	1995	2045	2095	2145	2195	2245	2295	2345	2395	2445	2495	2545	2595	2645	2695	2745	2795	2845	2895
A	50	100	50	100	50	100	50	100	50	100	50	100	50	100	50	100	50	100	50	100	50	100	50	100	50	100
M	14	14	15	15	16	16	17	17	18	18	19	19	20	20	21	21	22	22	23	23	24	24	25	25	26	26
N	34	34	36	36	38	38	40	40	42	42	44	44	46	46	48	48	50	50	52	52	54	54	56	56	58	58
KG	17.5	18.0	18.4	18.8	19.3	19.7	20.1	20.6	21.0	21.4	21.8	22.3	22.7	23.1	23.6	24.0	24.4	24.8	25.3	25.7	26.1	26.6	27.0	27.4	27.9	28.3

注：以上不含电机重量。
Note: Not including motor weight.

电机右上折-RU Motor Folds up on the Right

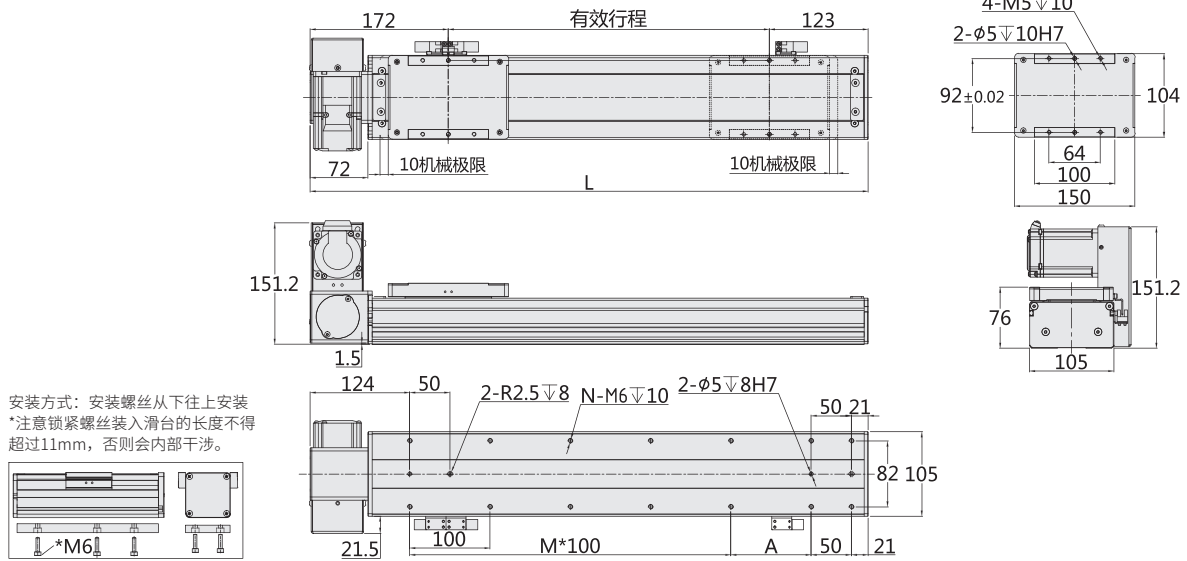

有效行程	50	100	150	200	250	300	350	400	450	500	550	600	650	700	750	800	850	900	950	1000	1050	1100	1150	1200	1250	1300
L	345	395	445	495	545	595	645	695	745	795	845	895	945	995	1045	1095	1145	1195	1245	1295	1345	1395	1445	1495	1545	1595
A	50	100	50	100	50	100	50	100	50	100	50	100	50	100	50	100	50	100	50	100	50	100	50	100	50	100
M	1	1	2	2	3	3	4	4	5	5	6	6	7	7	8	8	9	9	10	10	11	11	12	12	13	13
N	8	8	10	10	12	12	14	14	16	16	18	18	20	20	22	22	24	24	26	26	28	28	30	30	32	32
KG	6.4	6.8	7.2	7.7	8.1	8.5	9.0	9.4	9.8	10.2	10.7	11.1	11.5	12.0	12.4	12.8	13.3	13.7	14.1	14.5	15.0	15.4	15.8	16.3	16.7	17.1
有效行程	1350	1400	1450	1500	1550	1600	1650	1700	1750	1800	1850	1900	1950	2000	2050	2100	2150	2200	2250	2300	2350	2400	2450	2500	2550	2600
L	1645	1695	1745	1795	1845	1895	1945	1995	2045	2095	2145	2195	2245	2295	2345	2395	2445	2495	2545	2595	2645	2695	2745	2795	2845	2895
A	50	100	50	100	50	100	50	100	50	100	50	100	50	100	50	100	50	100	50	100	50	100	50	100	50	100
M	14	14	15	15	16	16	17	17	18	18	19	19	20	20	21	21	22	22	23	23	24	24	25	25	26	26
N	34	34	36	36	38	38	40	40	42	42	44	44	46	46	48	48	50	50	52	52	54	54	56	56	58	58
KG	17.5	18.0	18.4	18.8	19.3	19.7	20.1	20.6	21.0	21.4	21.8	22.3	22.7	23.1	23.6	24.0	24.4	24.8	25.3	25.7	26.1	26.6	27.0	27.4	27.9	28.3

注: 以上不含电机重量。
Note: Not including motor weight.

电机右下折-RD Motor Folds Down on the Right

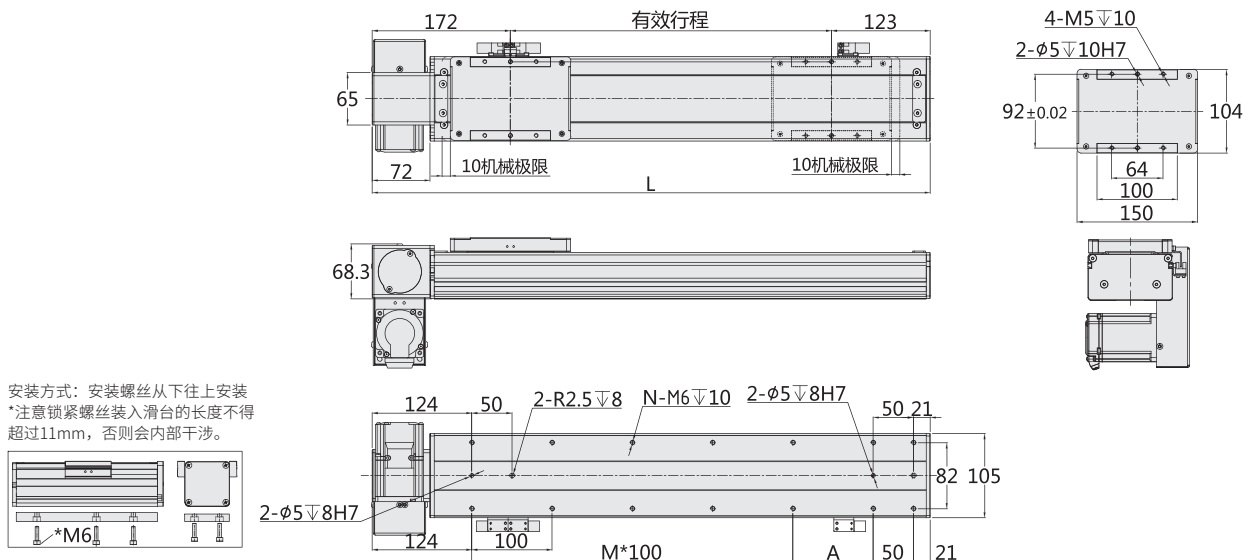

有效行程	50	100	150	200	250	300	350	400	450	500	550	600	650	700	750	800	850	900	950	1000	1050	1100	1150	1200	1250	1300
L	345	395	445	495	545	595	645	695	745	795	845	895	945	995	1045	1095	1145	1195	1245	1295	1345	1395	1445	1495	1545	1595
A	50	100	50	100	50	100	50	100	50	100	50	100	50	100	50	100	50	100	50	100	50	100	50	100	50	100
M	1	1	2	2	3	3	4	4	5	5	6	6	7	7	8	8	9	9	10	10	11	11	12	12	13	13
N	8	8	10	10	12	12	14	14	16	16	18	18	20	20	22	22	24	24	26	26	28	28	30	30	32	32
KG	6.4	6.8	7.2	7.7	8.1	8.5	9.0	9.4	9.8	10.2	10.7	11.1	11.5	12.0	12.4	12.8	13.3	13.7	14.1	14.5	15.0	15.4	15.8	16.3	16.7	17.1
有效行程	1350	1400	1450	1500	1550	1600	1650	1700	1750	1800	1850	1900	1950	2000	2050	2100	2150	2200	2250	2300	2350	2400	2450	2500	2550	2600
L	1645	1695	1745	1795	1845	1895	1945	1995	2045	2095	2145	2195	2245	2295	2345	2395	2445	2495	2545	2595	2645	2695	2745	2795	2845	2895
A	50	100	50	100	50	100	50	100	50	100	50	100	50	100	50	100	50	100	50	100	50	100	50	100	50	100
M	14	14	15	15	16	16	17	17	18	18	19	19	20	20	21	21	22	22	23	23	24	24	25	25	26	26
N	34	34	36	36	38	38	40	40	42	42	44	44	46	46	48	48	50	50	52	52	54	54	56	56	58	58
KG	17.5	18.0	18.4	18.8	19.3	19.7	20.1	20.6	21.0	21.4	21.8	22.3	22.7	23.1	23.6	24.0	24.4	24.8	25.3	25.7	26.1	26.6	27.0	27.4	27.9	28.3

注: 以上不含电机重量。
Note: Not including motor weight.