

丝杠模组 (半密封) -HS13

Lead Screw Module (semi-sealed)

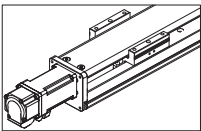

电机安装方式 How the Motor is Installed



电机直连外置-BC
Motor exposed

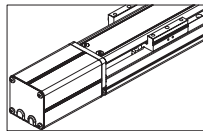

电机直连内置-M
Motor built-in

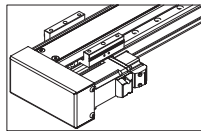

电机左折-BL
Motor left side

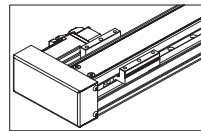

电机右折-BR
Motor right side

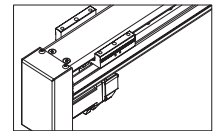

电机下折-BD
Motor bottom side

型号表示方式 Guide for Model Selection

Z-Mod-HS13-10-C7-100-BC-40SEB-N3-FXXX-01

HS13	10	C7	100	BC	40SE	B	N3	FXXX-01
本体型号 Base Model	丝杠导程 (螺距) Ball screw lead 5: 5mm 10: 10mm 20: 20mm 32: 32mm <small>*导程: 电机旋转一圈, 滑台移动的直线距离。</small>	精度等级 Accuracy class C7: 普通级C7 <small>Common precision</small> P5: 研磨级C5 <small>High precision</small>	行程 Stroke 50-1300mm	电机方式 Motor way BC: 直连外置 M: 直连内置 BL: 左折 BR: 右折 BD: 下折	电机功率 Motor power 20SE: 200W伺服 40SE: 400W伺服 57ST: 57步进	刹车 Brakes 无: 无电机 B: 一体式电机 (带刹车) M: 一体式电机	感应开关数量 Sensor quantity N3: 3个NPN传感器 N2: 2个NPN传感器 N1: 1个NPN传感器 P3: 3个PNP传感器 P2: 2个PNP传感器 P1: 1个PNP传感器 N: 无	特殊定制 Customer number F: 非标准定制选项, 若为标准品, 则为空 XXX: 客户标号 01: 版本号

基本参数 Parameters

电机功率 Motor power(w)	400W			
电机转速 Motor speed(rpm/min)	*3000			
滚珠丝杆导程-螺距 Belt lead(mm)	5	10	20	32
最高速度 Maximum payload(mm/s)	250	500	1000	1600
水平负载 Horizontal load	110	88	40	30
垂直负载 Vertical load	35	30	10	8
额定推力 Rated thrust(N)	1388	694	347	218
行程范围 Range of travel(mm)	50-1300MM/50行程递增			
丝杆外径 Screw diameter(mm)	Ø16 (Ø20)			Ø16
重复位置精度 Repeatability(mm)	C7(C)		C0.01	
	C5(P)		±0.006	
导轨规格 Guide specification	W15XH12-2支			
联轴器 Coupling	10x14(11)*			
感应器 Sensor	EE-SX674(NPN)			

*电机加减速时间为0.2S。

*Motor speed is 0.2S.

*标配丝杆Ø16，也可定制Ø20。

*如有特殊定制请先与技术人员联系。

*If you have special customization, please contact a technician first.

安装示意图 Installation Diagram

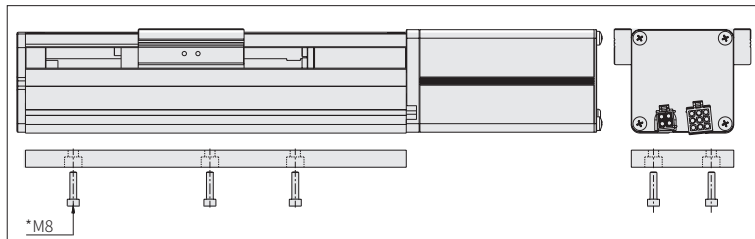

安装方式一：安装螺丝从下往上安装。

Installation method 1: The screws are installed from bottom to top.

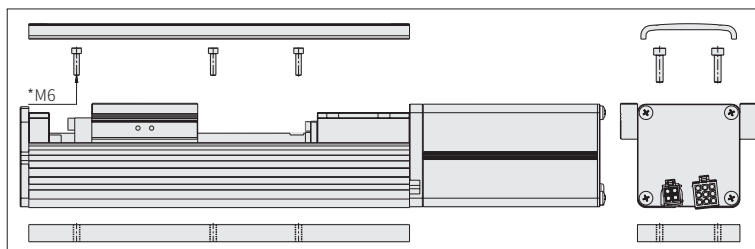

安装方式二：打开滑台上盖，安装螺丝从上往下安装。

Installation method 2: Open the sliding table cover and install the screws from top to bottom.

传感器接线图 Sensor Wiring Diagram

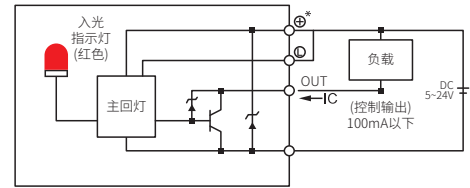

速度与行程 Speed and stroke

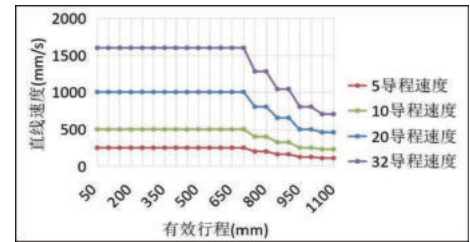

*行程超过750时，丝杆旋转会产生共振，此时请将速度调低。
*When the stroke is more than 750, the rotation of the screw will cause resonance, and then the speed will be lowered.

静态力矩表 Static Moment

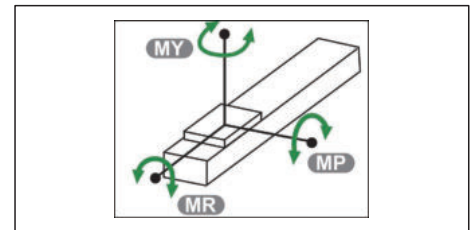

MY	551 (N.M)
MP	552 (N.M)
MR	485 (N.M)

电机左折-BL Motor Left Side

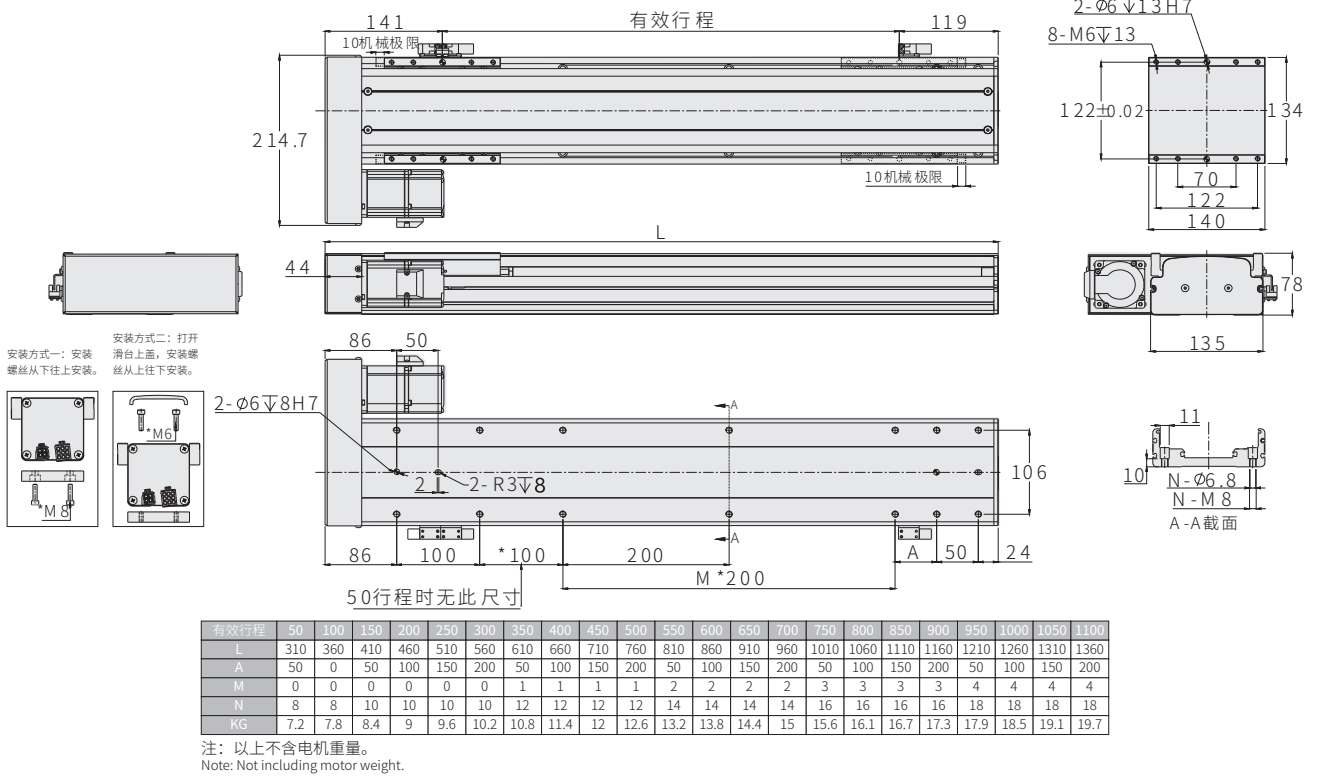

电机右折-BR Motor Right Side

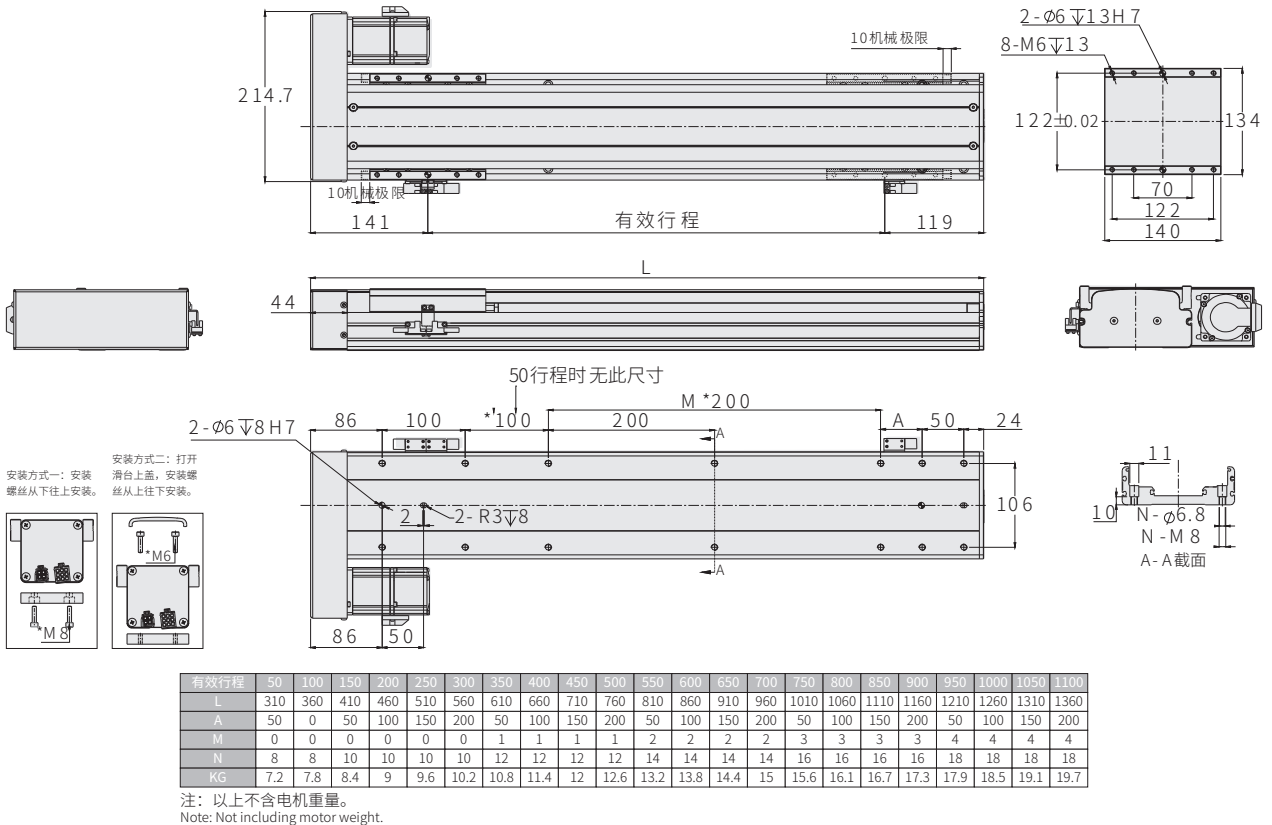

电机下折-BD Motor Bottom Side

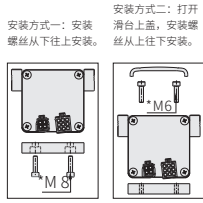
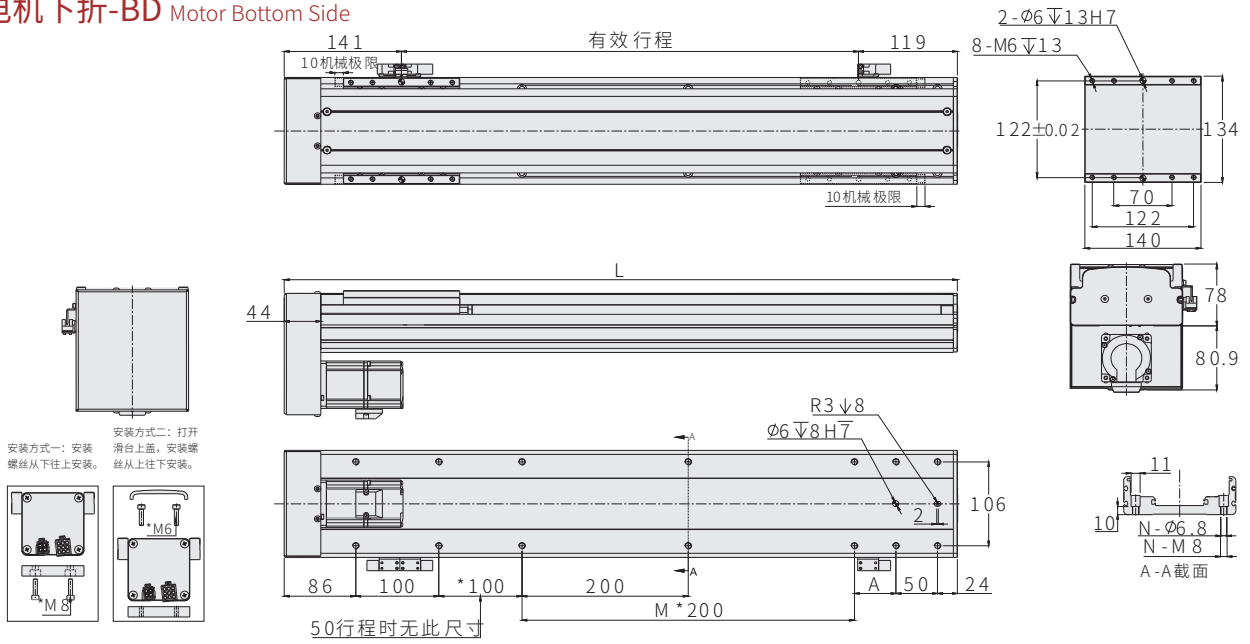

有效行程	50	100	150	200	250	300	350	400	450	500	550	600	650	700	750	800	850	900	950	1000	1050	1100
L	310	360	410	460	510	560	610	660	710	760	810	860	910	960	1010	1060	1110	1160	1210	1260	1310	1360
A	50	0	50	100	150	200	50	100	150	200	50	100	150	200	50	100	150	200	50	100	150	200
M	0	0	0	0	0	0	1	1	1	1	2	2	2	2	3	3	3	3	4	4	4	4
N	8	8	10	10	10	10	12	12	12	12	14	14	14	14	16	16	16	16	18	18	18	18
KG	7.4	8	8.6	9.2	9.8	10.4	11	11.6	12.2	12.8	13.2	14	14.6	15.2	15.8	16.3	16.9	17.5	18.1	18.5	19.3	19.9

注：以上不含电机重量。
Note: Not including motor weight.