

丝杠模组 (半密封) -HS22

Lead Screw Module (semi-sealed)

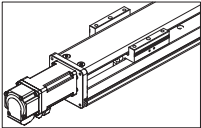

电机安装方式 How the Motor is Installed



电机直连外置-BC
Motor exposed

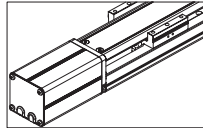

电机直连内置-M
Motor built-in

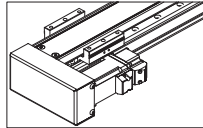

电机左折-BL
Motor left side

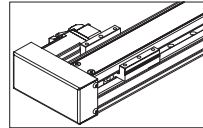

电机右折-BR
Motor right side

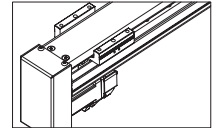

电机下折-BD
Motor bottom side

型号表示方式 Guide for Model Selection

Z-Mod-HS22-10-C7-100-BC-75SEB-N3-FXXX-01

HS22	10	C7	100	BC	75SE	B	N3	FXXX-01
本体型号 Base Model	丝杠导程 (螺距) Ball screw lead 5: 5mm 10: 10mm 25: 25mm 40: 40mm *导程: 电机旋转一圈, 滑台移动的直线距离。	精度等级 Accuracy class C7: 普通级C7 Common precision P5: 研磨级C5 High precision	行程 Stroke 50-2000mm	电机方式 Motor way BC: 直连外置 M: 直连内置 BL: 左折 BR: 右折 BD: 下折	电机功率 Motor power 75SE: 750W伺服 86ST: 86步进	刹车 Brakes 无: 无电机 B: 一体式电机 (带刹车) M: 一体式电机	感应开关数量 Sensor quantity N3: 3个NPN传感器 N2: 2个NPN传感器 N1: 1个NPN传感器 P3: 3个PNP传感器 P2: 2个PNP传感器 P1: 1个PNP传感器 N: 无	特殊定制 Customer number F: 非标定制选项, 若为标准品, 则为空 XXX: 客户标号 01: 版本号

基本参数 Parameters

电机功率 Motor power(w)	750W			
电机转速 Motor speed(rpm/min)	*3000			
滚珠丝杆导程-螺距 Belt lead(mm)	5	10	25	40
最高速度 Maximum payload(mm/s)	250	500	1250	2000
水平负载 Horizontal load	150	150	105	43
垂直负载 Vertical load	80	60	22	13
额定推力 Rated thrust(N)	2553	1281	600	320
行程范围 Range of travel(mm)	50-2000MM/50行程递增			
丝杆外径 Screw diameter(mm)	C7(C)		±0.01	
重复位置精度 Repeatability(mm)	C5(P)		±0.006	
	*Ø25		Ø20	
导轨规格 Guide specification	W23XH18-2支			
联轴器 Coupling	16x19		12x19	
感应器 Sensor	EE-SX674(NPN)			

*电机加减速时间为0.2S。

*Motor speed is 0.2S.

*标配丝杆Ø25，也可定制Ø32。

*如有特殊定制请先与技术人员联系。

*If you have special customization, please contact a technician first.

安装示意图 Installation Diagram

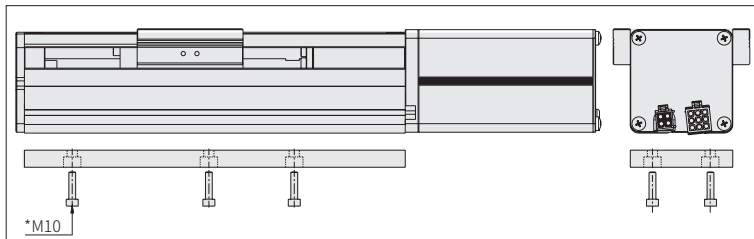

安装方式一：安装螺丝从下往上安装。

Installation method 1: The screws are installed from bottom to top.

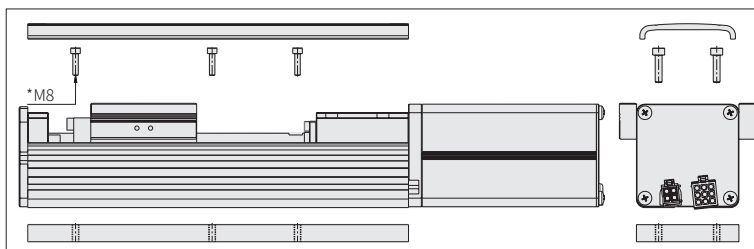

安装方式二：打开滑台上盖，安装螺丝从上往下安装。

Installation method 2: Open the sliding table cover and install the screws from top to bottom.

传感器接线图 Sensor Wiring Diagram

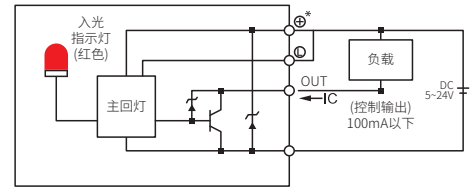

速度与行程 Speed and stroke

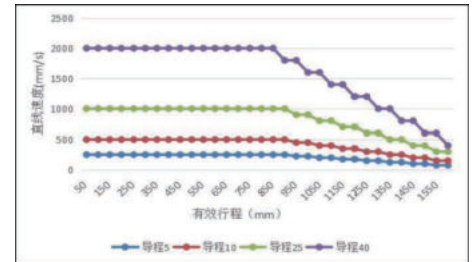

*行程超过900时，丝杆旋转会产生共振，此时请将速度调低。

*When the stroke is more than 900, the rotation of the screw will cause resonance, and then the speed will be lowered.

静态力矩表 Static Moment

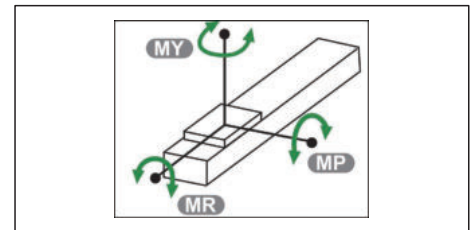

MY 2050 (N.M)

MP 2050 (N.M)

MR 1810 (N.M)

电机直连外置-BC Motor Exposed

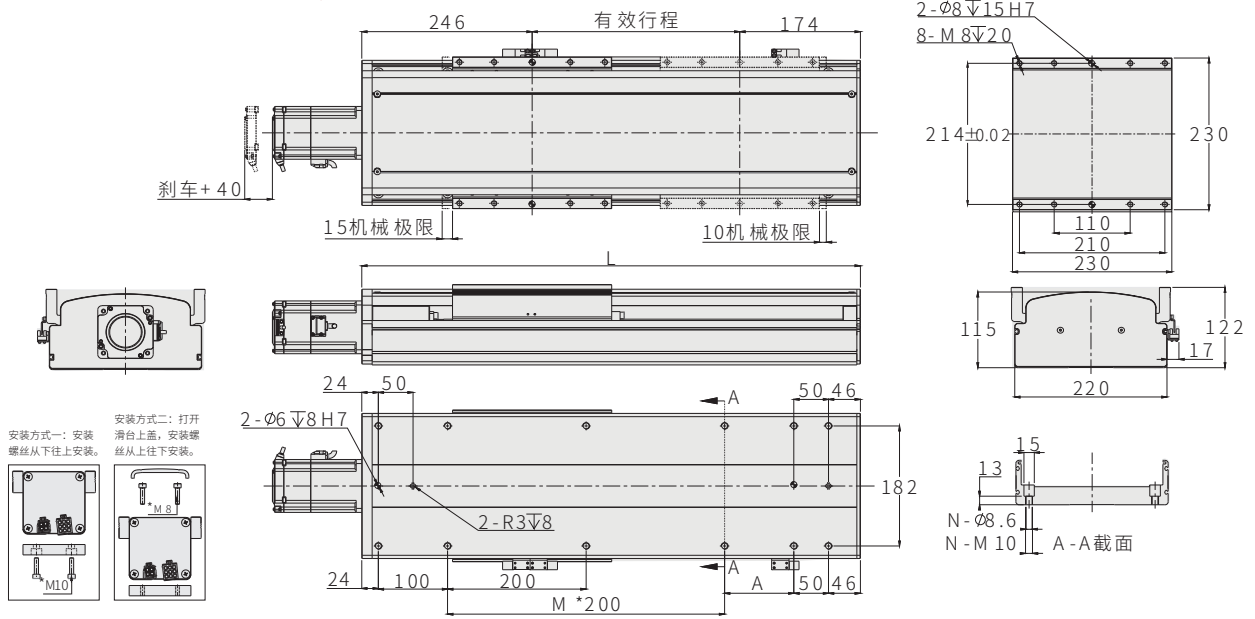

有效行程	50	100	150	200	250	300	350	400	450	500	550	600	650	700	750	800	850	900	950	1000	1050	1100	1150	1200	1250	1300	1350	1400	1450	1500	1550	1600
L	470	520	570	620	670	720	770	820	870	920	970	1020	1070	1120	1170	1220	1270	1320	1370	1420	1470	1520	1570	1620	1670	1720	1770	1820	1870	1920	1970	2020
A	50	100	150	200	50	100	150	200	50	100	150	200	50	100	150	200	50	100	150	200	50	100	150	200	50	100	150	200	50	100	150	200
M	1	1	1	1	2	2	2	2	3	3	3	3	4	4	4	4	5	5	5	5	6	6	6	6	6	7	7	7	7	8	8	8
N	10	10	10	10	12	12	12	12	14	14	14	14	16	16	16	16	18	18	18	18	20	20	20	20	22	22	22	22	24	24	24	24
KG	25.4	26.8	28.3	29.8	31.2	32.7	34.2	35.6	37.1	38.5	40.0	41.5	42.9	44.4	45.8	47.3	48.8	50.2	51.7	53.1	54.6	56.1	57.5	59.0	60.4	61.9	63.4	64.8	66.3	67.7	69.2	70.6

注：以上不含电机重量。
Note: Not including motor weight.

电机直连内置-M Motor Built-in

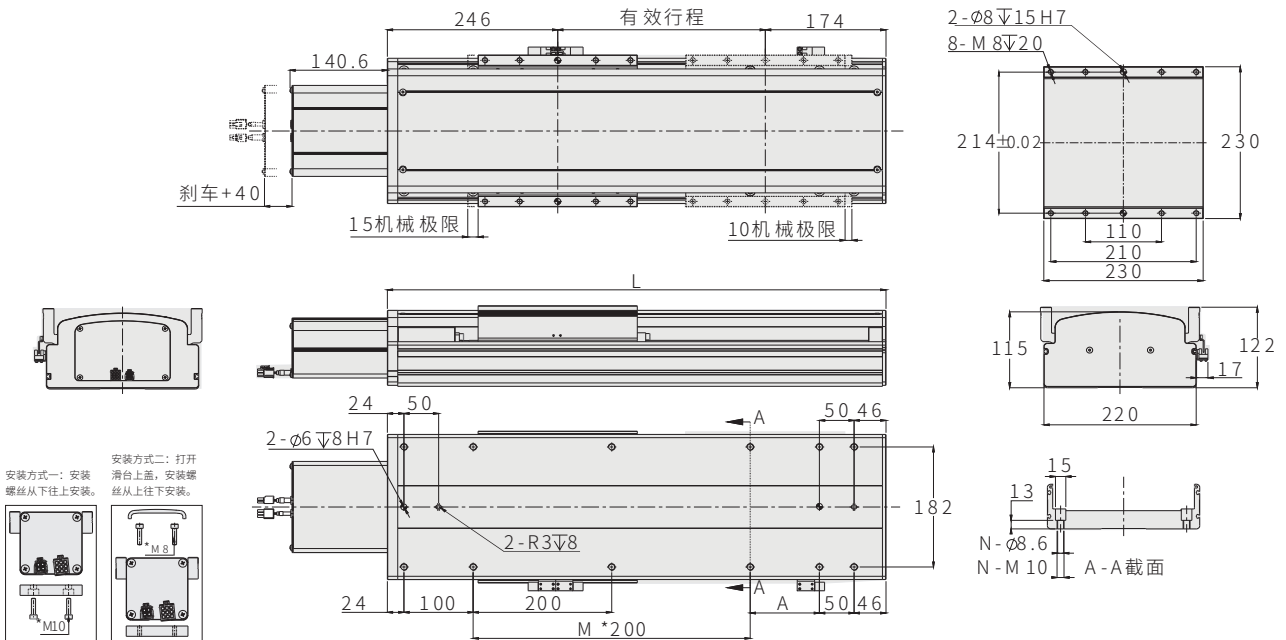

有效行程	50	100	150	200	250	300	350	400	450	500	550	600	650	700	750	800	850	900	950	1000	1050	1100	1150	1200	1250	1300	1350	1400	1450	1500	1550	1600
L	470	520	570	620	670	720	770	820	870	920	970	1020	1070	1120	1170	1220	1270	1320	1370	1420	1470	1520	1570	1620	1670	1720	1770	1820	1870	1920	1970	2020
A	50	100	150	200	50	100	150	200	50	100	150	200	50	100	150	200	50	100	150	200	50	100	150	200	50	100	150	200	50	100	150	200
M	1	1	1	1	2	2	2	2	3	3	3	3	4	4	4	4	5	5	5	5	6	6	6	6	6	7	7	7	7	8	8	8
N	10	10	10	10	12	12	12	12	14	14	14	14	16	16	16	16	18	18	18	18	20	20	20	20	22	22	22	22	24	24	24	24
KG	25.7	27.1	28.6	31.2	31.5	33.0	34.5	35.9	37.4	38.8	40.3	41.8	43.2	44.7	46.1	47.6	49.1	50.5	52.0	53.4	54.9	56.4	57.8	59.3	60.7	62.2	63.7	65.1	66.6	68.0	69.5	70.9

注：以上不含电机重量。
Note: Not including motor weight.

电机左折-BL Motor Left Side

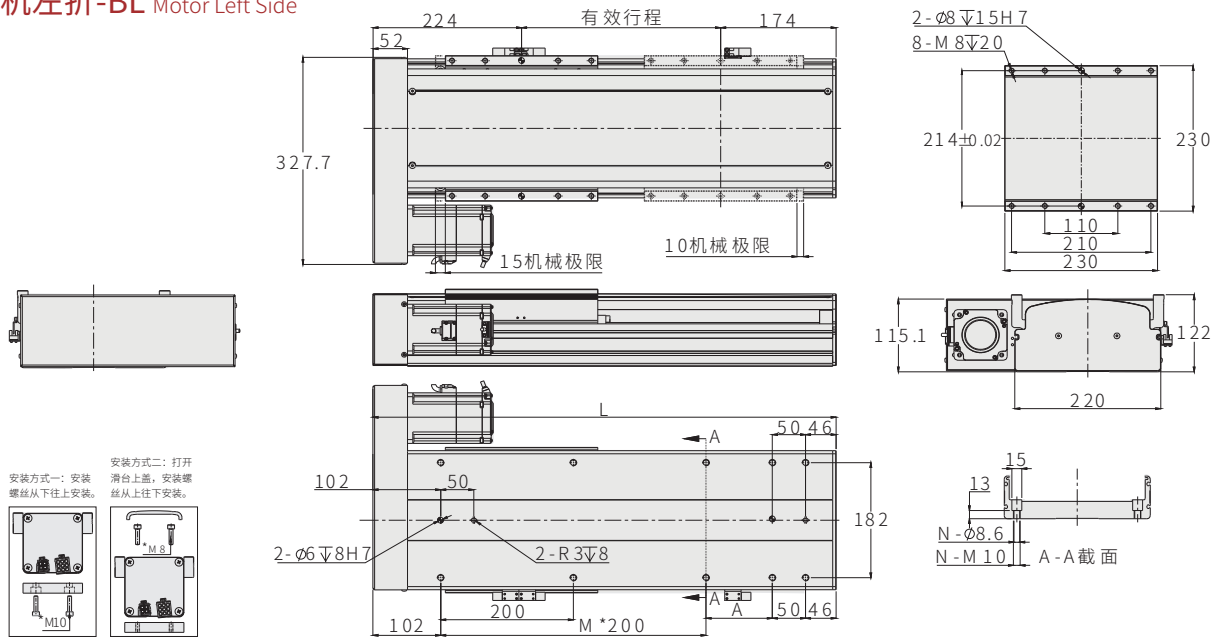

有效行程	50	100	150	200	250	300	350	400	450	500	550	600	650	700	750	800	850	900	950	1000	1050	1100	1150	1200	1250	1300	1350	1400	1450	1500	1550	1600
L	448	498	548	598	648	698	748	798	848	898	948	998	1048	1098	1148	1198	1248	1298	1348	1398	1448	1498	1548	1598	1648	1698	1748	1798	1848	1898	1948	1998
A	50	100	150	200	50	100	150	200	50	100	150	200	50	100	150	200	50	100	150	200	50	100	150	200	50	100	150	200	50	100	150	200
M	1	1	1	1	2	2	2	2	3	3	3	3	4	4	4	4	5	5	5	5	6	6	6	6	7	7	7	7	8	8	8	8
N	8	8	8	8	10	10	10	10	12	12	12	12	14	14	14	14	16	16	16	16	18	18	18	18	20	20	20	20	22	22	22	22
KG	24.4	25.8	27.3	28.8	30.2	31.7	33.2	34.6	36.1	37.5	39.0	40.5	41.9	43.4	44.8	46.3	47.8	49.2	50.7	52.1	53.6	55.1	56.5	58.0	59.4	60.9	62.4	63.8	65.3	66.7	68.2	69.6

注: 以上不含电机重量。
 Note: Not including motor weight.

电机右折-BR Motor Right Side

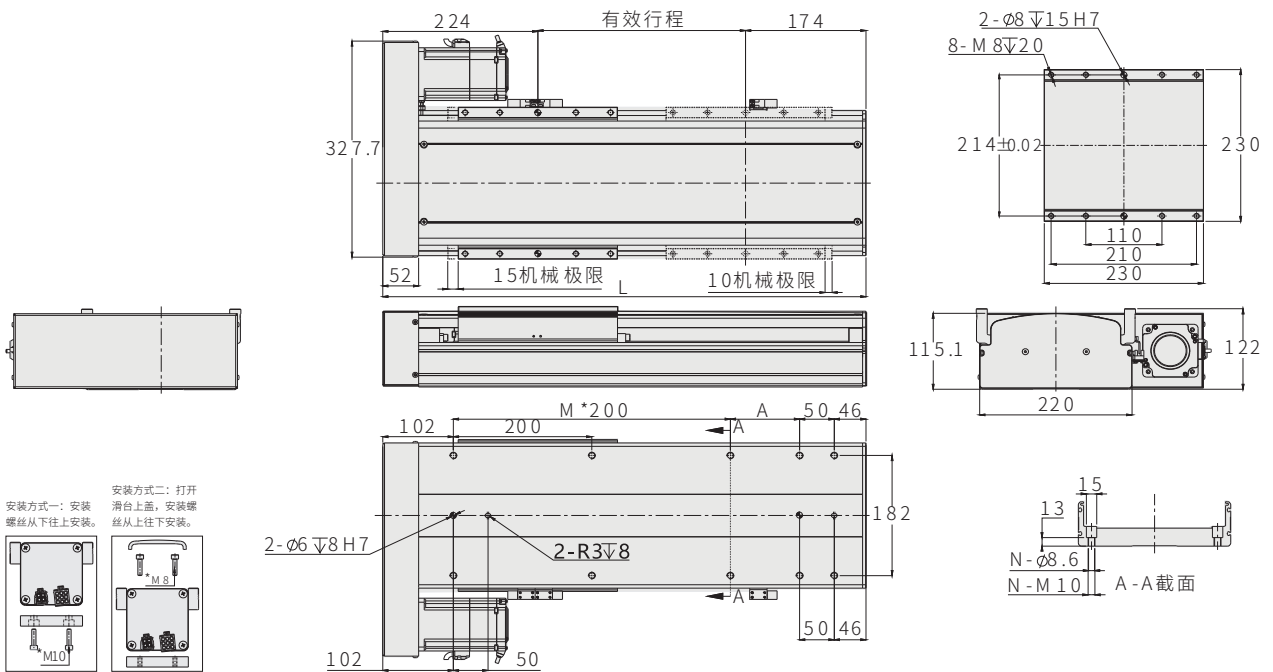

有效行程	50	100	150	200	250	300	350	400	450	500	550	600	650	700	750	800	850	900	950	1000	1050	1100	1150	1200	1250	1300	1350	1400	1450	1500	1550	1600
L	448	498	548	598	648	698	748	798	848	898	948	998	1048	1098	1148	1198	1248	1298	1348	1398	1448	1498	1548	1598	1648	1698	1748	1798	1848	1898	1948	1998
A	50	100	150	200	50	100	150	200	50	100	150	200	50	100	150	200	50	100	150	200	50	100	150	200	50	100	150	200	50	100	150	200
M	1	1	1	1	2	2	2	2	3	3	3	3	4	4	4	4	5	5	5	5	6	6	6	6	7	7	7	7	8	8	8	8
N	8	8	8	8	10	10	10	10	12	12	12	12	14	14	14	14	16	16	16	16	18	18	18	18	20	20	20	20	22	22	22	22
KG	24.4	25.8	27.3	28.8	30.2	31.7	33.2	34.6	36.1	37.5	39.0	40.5	41.9	43.4	44.8	46.3	47.8	49.2	50.7	52.1	53.6	55.1	56.5	58.0	59.4	60.9	62.4	63.8	65.3	66.7	68.2	69.6

注: 以上不含电机重量。
 Note: Not including motor weight.

电机下折-BD Motor Bottom Side

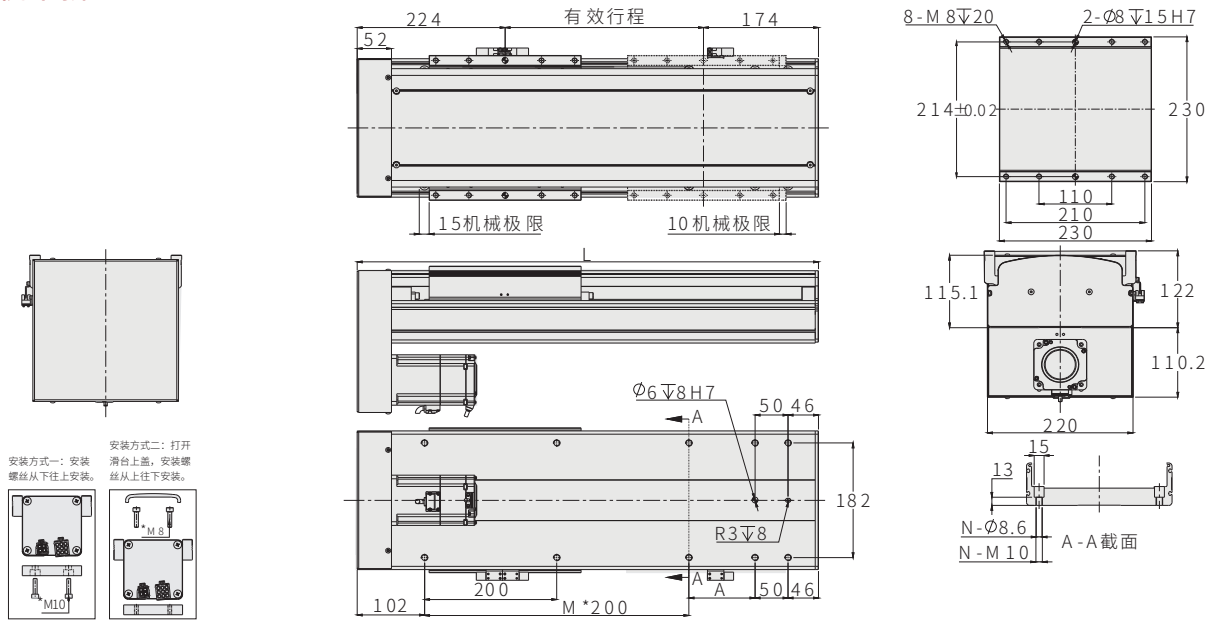

有效行程	50	100	150	200	250	300	350	400	450	500	550	600	650	700	750	800	850	900	950	1000	1050	1100	1150	1200	1250	1300	1350	1400	1450	1500	1550	1600
L	448	498	548	598	648	698	748	798	848	898	948	998	1048	1098	1148	1198	1248	1298	1348	1398	1448	1498	1548	1598	1648	1698	1748	1798	1848	1898	1948	1998
A	50	100	150	200	50	100	150	200	50	100	150	200	50	100	150	200	50	100	150	200	50	100	150	200	50	100	150	200	50	100	150	200
M	1	1	1	1	2	2	2	2	3	3	3	3	4	4	4	4	5	5	5	5	6	6	6	6	7	7	7	7	8	8	8	8
N	8	8	8	8	10	10	10	10	12	12	12	12	14	14	14	14	16	16	16	16	18	18	18	18	20	20	20	20	22	22	22	22
KG	24.4	25.8	27.3	28.8	30.2	31.7	33.2	34.6	36.1	37.5	39.0	40.5	41.9	43.4	44.8	46.3	47.8	49.2	50.7	52.1	53.6	55.1	56.5	58.0	59.4	60.9	62.4	63.8	65.3	66.7	68.2	69.6

注: 以上不含电机重量。
Note: Not including motor weight.