

# 内嵌丝杠模组 (半密封)-HSK8

Embedded Screw Module (semi-sealed)

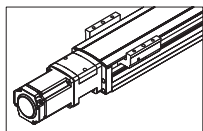

## 电机安装方式 How the Motor is Installed



电机直连外置-BC  
Motor exposed

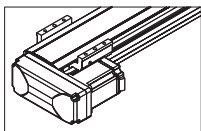

电机左折-BL  
Motor left side

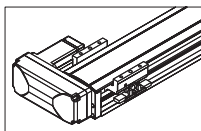

电机右折-BR  
Motor right side

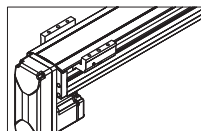

电机下折-BD  
Motor bottom side

## 型号表示方式 Guide for Model Selection

# Z-Mod-HSK8-10-C7-100-BC-40SEB-N3-FXXX-01

HSK8	10	C7	100	BC	40SE	B	N3	FXXX-01
本体型号 Base Model	丝杆导程 (螺距) Ball screw lead 5: 5mm 10: 10mm 20: 20mm  <small>*导程: 电机旋转一圈, 滑台移动的真丝距离。</small>	精度等级 Accuracy class C7: 普通级C7 Common precision P5: 研磨级C5 High precision	行程 Stroke 50-1050mm	电机方式 Motor way BC: 直连外置 BL: 左折 BR: 右折 BD: 下折	电机功率 Motor power 20SE: 200W伺服 40SE: 400W伺服	刹车 Brakes 无: 无电机 B: 一体式电机 (带刹车) M: 一体式电机	感应开关数量 Sensor quantity N3: 3个NPN传感器 N2: 2个NPN传感器 N1: 1个NPN传感器 P3: 3个PNP传感器 P2: 2个PNP传感器 P1: 1个PNP传感器 N: 无	特殊定制 Customized service F: 非标准定制选项, 若为标准品, 则为空 XXX: 客户标号 01: 版本号

## 基本参数 Parameters

电机功率 Motor power(w)	200W(400W)		
电机转速 Motor speed(rpm/min)	3000		
滚珠丝杆导程-螺距 Belt lead(mm)	5	10	20
最高速度 Maximum payload(mm/s)	250	500	1000
水平负载 Horizontal load	50	40	20
垂直负载 Vertical load	20	15	6
额定推力 Rated thrust(n)	683	341	174
行程范围 Range of travel(mm)	50-1050MM/50行程递增		
丝杆外径 Screw diameter(mm)	Ø16		
重复位置精度 Repeatability(mm)	C7(C)	±0.01	
	C5(P)	±0.006	
联轴器 Coupling	10x14		
感应器 Sensor	EE-SX674(NPN)		

\*电机加减速时间为0.2S。

\*Motor speed is 0.2S.

\*如有特殊定制请先与技术人员联系。

\*if you have customization requirements, please contact our technician first.

## 传感器接线图 Sensor Wiring Diagram

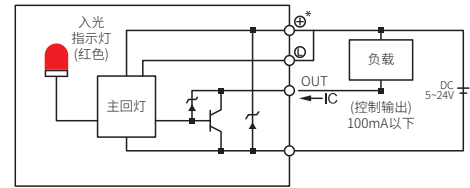

## 速度与行程 Speed and stroke

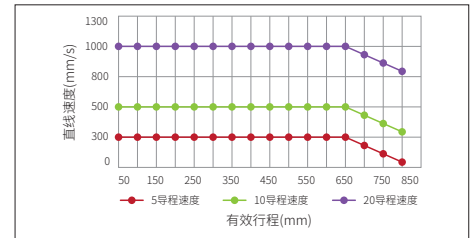

\*行程超过600时，丝杆旋转会产生共振，此时请将速度调低。  
\*When the stroke is more than 600, the rotation of the screw will cause resonance, and then the speed will be lowered.

## 安装示意图 Installation Diagram

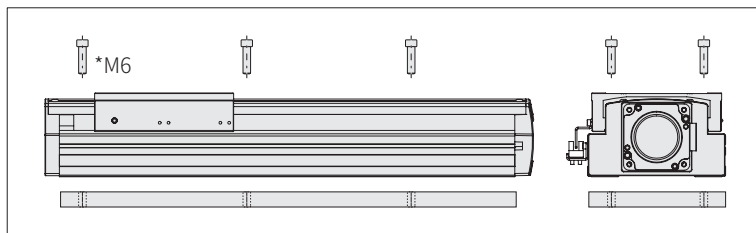

安装方式：安装螺丝从上往下安装。  
Installation method 1: Screws are installed from top to bottom.

## 静态力矩表 Static Moment

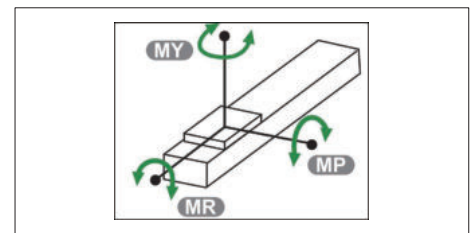

MY	287 (N.m)
MP	287 (N.m)
MR	626 (N.m)

## 电机直连外置-BC Motor Exposed

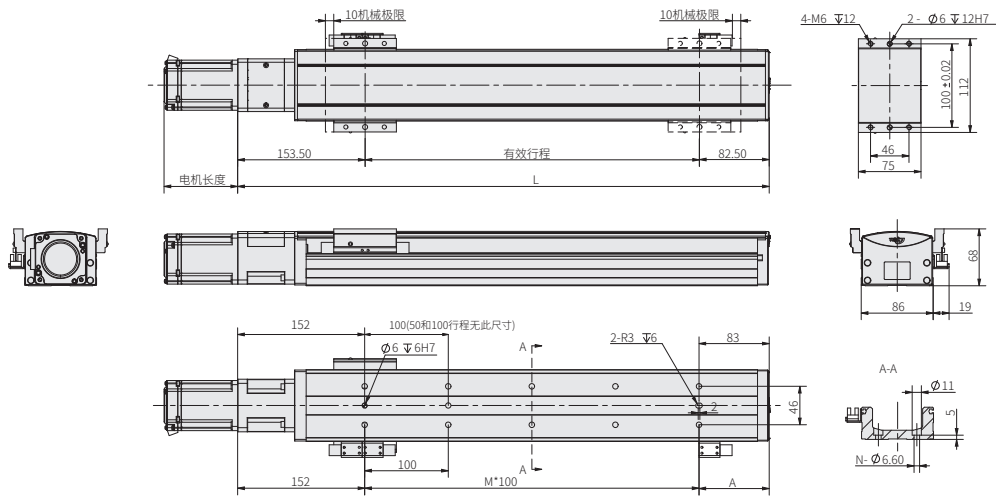

有效行程	50	100	150	200	250	300	350	400	450	500	550	600	650	700	750	800	850	900	950	1000	1050
L	285	335	385	435	485	535	585	635	685	735	785	835	885	935	985	1035	1085	1135	1185	1235	1285
A	33	83	33	83	33	83	33	83	33	83	33	83	33	83	33	83	33	83	33	83	33
M	1	1	2	2	3	3	4	4	5	5	6	6	7	7	8	8	9	9	10	10	11
N	4	4	6	6	8	8	10	10	12	12	14	14	16	16	18	18	20	20	22	22	24
KG	5.23	5.63	6.03	6.43	6.83	7.23	7.63	8.03	8.43	8.83	9.23	9.63	10.03	10.43	10.83	11.23	11.63	12.03	12.43	12.83	13.23

注：以上不含电机重量。  
Note: Not including motor weight.

## 电机左折-BL Motor Left Side

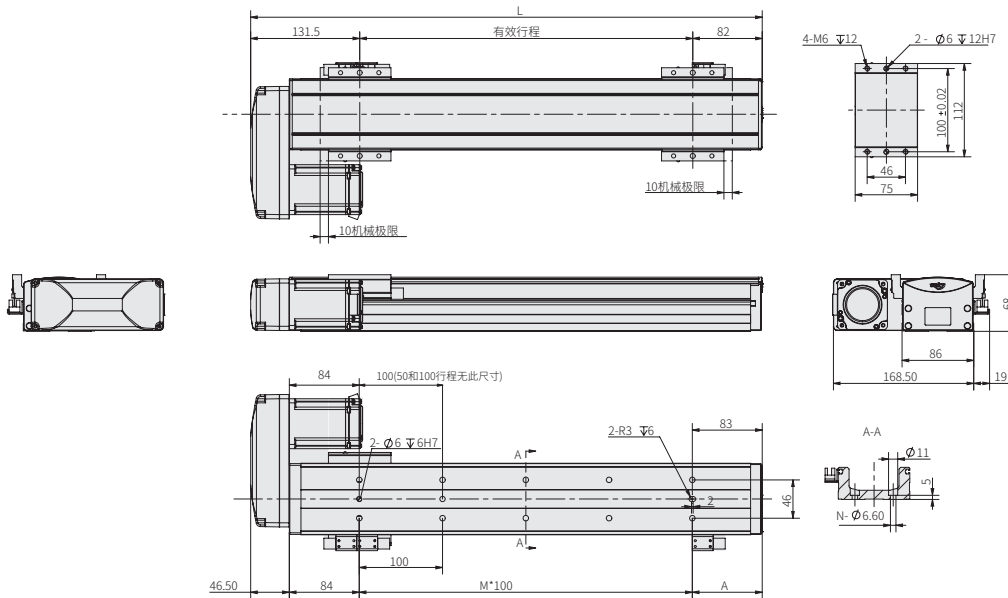

有效行程	50	100	150	200	250	300	350	400	450	500	550	600	650	700	750	800	850	900	950	1000	1050
L	263.5	313.5	363.5	413.5	463.5	513.5	563.5	613.5	663.5	713.5	763.5	813.5	863.5	913.5	963.5	1013.5	1063.5	1113.5	1163.5	1213.5	1263.5
A	33	83	33	83	33	83	33	83	33	83	33	83	33	83	33	83	33	83	33	83	33
M	1	1	2	2	3	3	4	4	5	5	6	6	7	7	8	8	9	9	10	10	11
N	4	4	6	6	8	8	10	10	12	12	14	14	16	16	18	18	20	20	22	22	24
KG	5.24	5.7	6.2	6.58	6.98	7.38	7.78	8.18	8.58	8.98	9.38	9.78	10.18	10.58	10.98	11.38	11.78	12.18	12.58	12.98	13.38

注：以上不含电机重量。  
Note: Not including motor weight.

## 电机右折-BR Motor Right Side

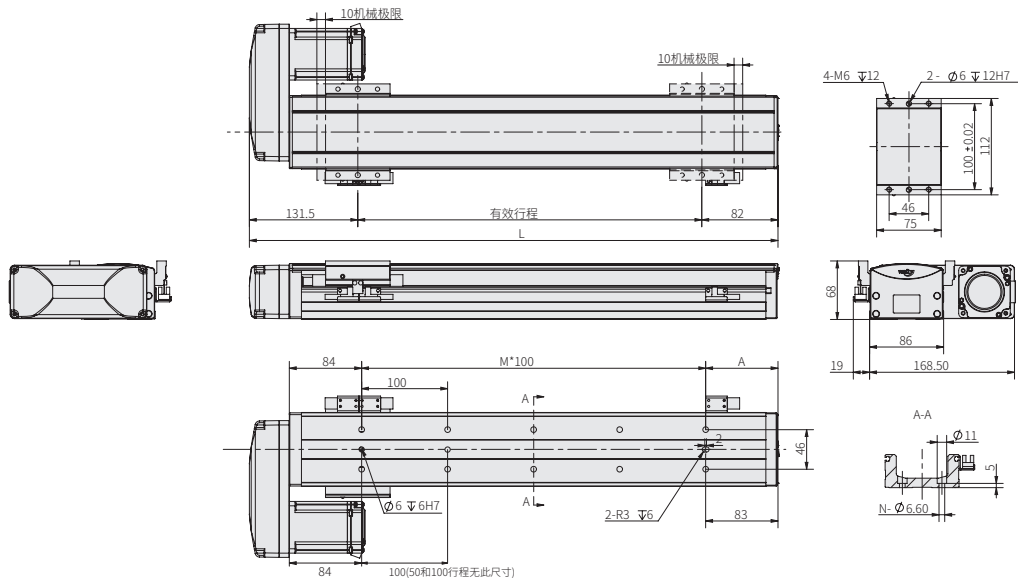

有效行程	50	100	150	200	250	300	350	400	450	500	550	600	650	700	750	800	850	900	950	1000	1050
L	263.5	313.5	363.5	413.5	463.5	513.5	563.5	613.5	663.5	713.5	763.5	813.5	863.5	913.5	963.5	1013.5	1063.5	1113.5	1163.5	1213.5	1263.5
A	33	83	33	83	33	83	33	83	33	83	33	83	33	83	33	83	33	83	33	83	33
M	1	1	2	2	3	3	4	4	5	5	6	6	7	7	8	8	9	9	10	10	11
N	4	4	6	6	8	8	10	10	12	12	14	14	16	16	18	18	20	20	22	22	24
KG	5.24	5.7	6.2	6.58	6.98	7.38	7.78	8.18	8.58	8.98	9.38	9.78	10.18	10.58	10.98	11.38	11.78	12.18	12.58	12.98	13.38

注：以上不含电机重量。  
Note: Not including motor weight.

## 电机下折-BD Motor Bottom Side

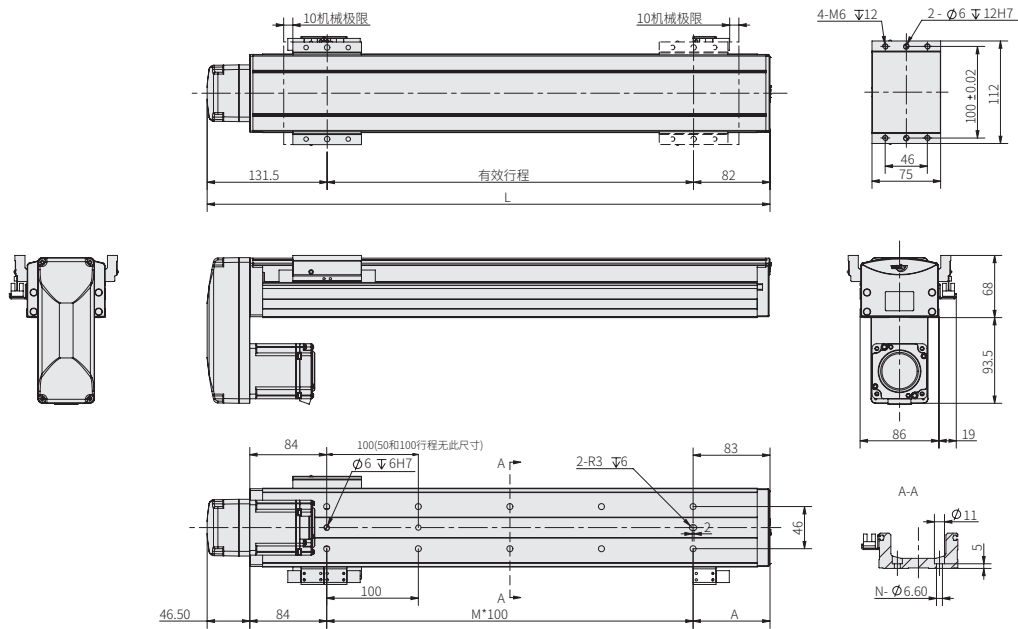

有效行程	50	100	150	200	250	300	350	400	450	500	550	600	650	700	750	800	850	900	950	1000	1050
L	263.5	313.5	363.5	413.5	463.5	513.5	563.5	613.5	663.5	713.5	763.5	813.5	863.5	913.5	963.5	1013.5	1063.5	1113.5	1163.5	1213.5	1263.5
A	33	83	33	83	33	83	33	83	33	83	33	83	33	83	33	83	33	83	33	83	33
M	1	1	2	2	3	3	4	4	5	5	6	6	7	7	8	8	9	9	10	10	11
N	4	4	6	6	8	8	10	10	12	12	14	14	16	16	18	18	20	20	22	22	24
KG	5.24	5.7	6.2	6.58	6.98	7.38	7.78	8.18	8.58	8.98	9.38	9.78	10.18	10.58	10.98	11.38	11.78	12.18	12.58	12.98	13.38

注：以上不含电机重量。  
Note: Not including motor weight.